



User Guide

Open-Loop Elevator AC Drive

Cotents

Safety Information and Precautions	2
1 Product information.....	4
1.1 Designation Rule and Nameplate.....	5
1.2 General specifications.....	6
2 Wiring.....	7
2.1 Typical wiring 1 (use multi-reference input as frequency reference).....	7
2.2 Terminal description.....	8
3 Operation panel.....	9
3.1 Get familiar with operation panel.....	9
4 Quick setup.....	13
4.1 Complete timing diagram for normal travel (use multi-reference as frequency reference).....	13
4.2 Elevator performance fine tuning.....	14
4.3 Setup flowchart.....	16
4.4 IGBT Enable.....	20
5 Function code table.....	23
5.1 Group F0: fundamental.....	23
5.2 Group F1: motor 1 parameters.....	24
5.3 Group F2: vector control.....	25
5.4 Group F3: VF control.....	26
5.5 Group F4: input terminals.....	27
5.6 Group F5: output terminals.....	29
5.7 Group F6: start and stop control.....	30
5.8 Group F7: product and software version checking.....	30
5.9 Group F8: auxiliary functions.....	31
5.10 Group F9: fault and protection.....	31
5.11 Group FC: multi-reference.....	32
5.12 Group FF: drive parameters.....	32
5.13 Group FP: function code management.....	33
5.14 Group A5: control optimization.....	33
5.15 Group U0: monitoring.....	33
6 Trouble shooting.....	35
6.1 Inverter fault codes.....	35
6.2 Inverter common symptoms and diagnostics.....	37

Safety Information and Precautions

This User Guide is packaged together with the Elevator AC Drive. It contains basic information for quick start of the drive.

- **Electrical Safety**

Extreme care must be taken at all times when working with the AC Drive or within the area of the AC Drive. The voltages used in the AC Drive can cause severe electrical shock or burns and is potentially lethal. Only authorized and qualified personnel should be allowed to work on AC Drives.

- **Machine/System Design and Safety of Personnel**

Machine/system design, installation, commissioning startups and maintenance must be carried out by personnel who have the necessary training and experience. They must read this safety information and the contents of this manual. If incorrectly installed, the AC Drive may present a safety hazard.

The AC Drive uses high voltages and currents (including DC), carries a high level of stored electrical energy in the DC bus capacitors even after power OFF. These high voltages are potentially lethal.

The AC Drive is NOT intended to be used for safety related applications/functions. The electronic "STOP & START" control circuits within the AC Drive must not be relied upon for the safety of personnel. Such control circuits do not isolate mains power voltages from the output of the AC Drive. The mains power supply must be disconnected by an electrical safety isolation device before accessing the internal parts of the AC Drive.

Safety risk assessments of the machine or process system which uses an AC Drive must be undertaken by the user and or by their systems integrator/designer. In particular the safety assessment/design must take into consideration the consequences of the AC Drive failing or tripping out during normal operation and whether this leads to a safe stop position without damaging machine, adjacent equipment and machine operators/users. This responsibility lies with the user or their machine/process system integrator.

System integrator/designer must ensure the complete system is safe and designed according to the relevant safety standards. Inovance Technology and Authorized Distributors can provide recommendations related to the AC drive to ensure long term safe operation.

The installer of the AC Drive is responsible for complying with all relevant regulations for wiring, circuit fuse protection, earthing, accident prevention and electromagnetic (EMC regulations). In particular fault discrimination for preventing fire risk and solid earthing practices must be adhered to for electrical safety (also for good EMC performance). Within the European Union, all machinery in which this product is used must comply with required directives.

- **Electrical Installation - Safety**

Electrical shock risk is always present within an AC Drive including the output cable leading to the motor terminals. Where dynamic brake resistors are fitted external to the AC Drive, care must be taken with regards to live contact with the brake resistors, terminals which are at high DC voltage and potentially lethal. Cables from the AC Drive to the dynamic brake resistors should be double insulated as DC voltages are typically 600 to 700 VDC.

Mains power supply isolation switch should be fitted to the AC Drive. The mains power supply must be disconnected via the isolation switch before any cover of the AC Drive can be removed or before any servicing work is undertaken stored charge in the DC bus capacitors of the PWM inverter is potentially lethal after the AC supply has been disconnected. The AC supply must be isolated at least 10 minutes before any work can be undertaken as the stored charge will have been discharged through the internal bleed resistor fitted across the DC bus capacitors.

Whenever possible, it is good practice to check DC bus voltage with a VDC meter before accessing the inverter bridge. Where the AC Drive input is connected to the mains supply with a plug and socket, then upon disconnecting the plug and socket, be aware that the plug pins may be exposed and internally connected to DC bus capacitors (via the internal bridge rectifier in reversed bias). Wait 10 minutes to allow stored charge in the DC bus capacitors to be dissipated by the bleed resistors before commencing work on the AC Drive.

- **Electrical Shock Hazard**

Ensure the protective earthing conductor complies with technical standards and local safety regulations. Because the leakage current exceeds 3.5 mA in all models, IEC 61800-5-1 states that either the power supply must be automatically disconnected in case of discontinuity of the protective earthing conductor or a protective earthing conductor with a cross-section of at least 10 mm² (Cu) or 16 mm² (Al) must be used. Failure to comply may result in death or serious injury.

When using an earth leakage circuit breaker, use a residual current operated protective device (RCD) of type B (breaker which can detect both AC and DC). Leakage current can cause unprotected components to operate incorrectly. If this is a problem, lower the carrier frequency, replace the components in question with parts protected against harmonic current, or increase the sensitivity amperage of the leakage breaker to at least 200 mA per drive.

- Factors in determining leakage current:
 - Size of the AC drive
 - AC drive carrier frequency
 - Motor cable type and length
 - EMI/RFI filter
- Approvals

Approvals

Certification marks on the product nameplate indicate compliance with the corresponding certificates and standards.

Certification	Mark	Directives		Standard
CE		EMC directives	2014/30/EU	EN 12015 EN 12016
		LVD directives	2014/35/EU	EN 61800-5-1
		RoHS directives	2011/65/EU	EN 50581

NOTE:

- The above EMC directives are complied with only when the EMC electric installation requirements are strictly observed.
- Machines and devices used in combination with this drive must also be CE certified and marked. The integrator who integrates the drive with the CE mark into other devices has the responsibility of ensuring compliance with CE standards and verifying that conditions meet European standards.
The installer of the drive is responsible for complying with all relevant regulations for wiring, circuit fuse protection, earthing, accident prevention and electromagnetic (EMC regulations). In particular fault discrimination for preventing fire risk and solid earthing practices must be adhered to for electrical safety (also for good EMC practice).
- For more information on certification, consult our distributor or sales representative.

1 Product information

1.1 Designation Rule and Nameplate

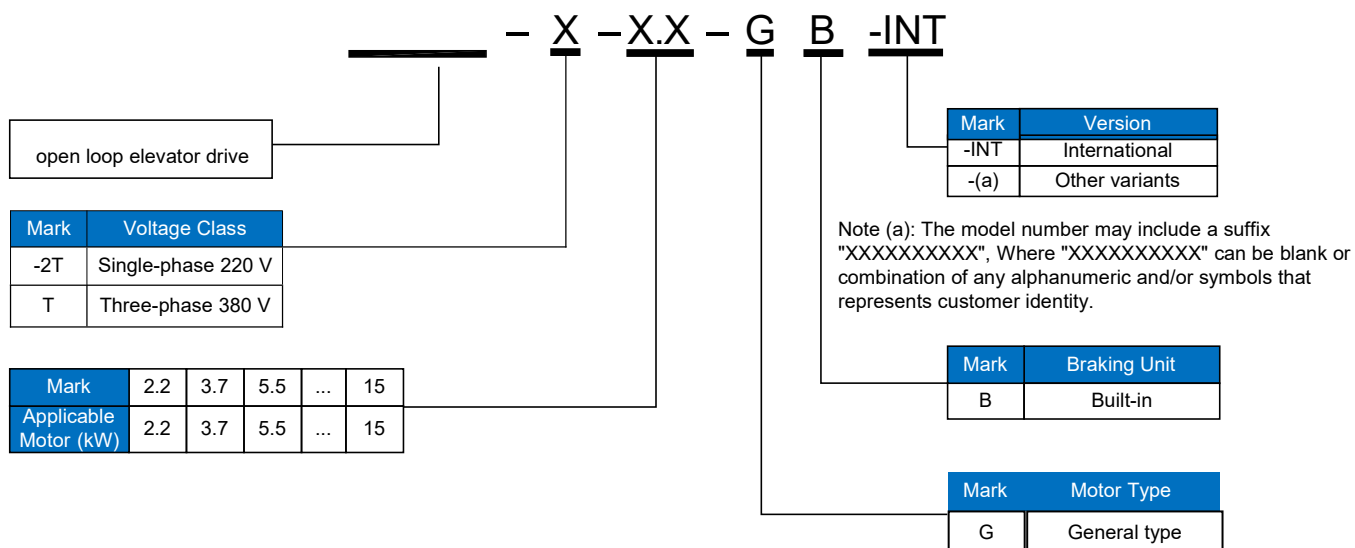

Nameplate	
Product name	PRODUCT: Elevator AC Drive
Model	MODEL: T3.7GB-INT
Rated input	INPUT: 3PH AC380-480V 10.5A 50/60Hz
Rated output	OUTPUT: 3PH AC0-440V 9A 0-100Hz 3.7kW
Serial No.	Serial No. : 010 140 374 FB 0005
Manufacturer	 Made in China

1.2 General specifications

Voltage class		220VAC				380/400/415VAC					
Drive Model		-2T2.2GB	-2T3.7GB	-2T5.5GB	-2T7.5GB	T3.7GB	T5.5GB	T7.5GB	T11GB	T15GB	
Dimension	Height	[H] : 248 mm		[H] : 322 mm		[H] : 248 mm		[H] : 322 mm			
	Width	[W] : 160 mm		[W] : 208 mm		[W] : 160 mm		[W] : 208 mm			
	Depth	[D] : 183 mm		[D] : 192 mm		[D] : 183 mm		[D] : 192 mm			
Mounting Hole		∅5		∅6		∅5		∅6			
Drive Input	Rated Input Voltage	Three-phase 200Vac to 240Vac, -15% to +10% (170Vac to 264Vac)				Three-phase 380 to 480V, -15% to +10% (323Vac to 528Vac)					
	Rated Input Current, [A]	10.5	14.6	26	35	10.5	14.6	20.5	26	35	
	Rated input frequency	50/60 Hz, ±5% (47.5 to 63Hz)									
Drive Output	Applicable Motor	[kW]	2.2	3.7	5.5	7.5	3.7	5.5	7.5	11	15
		[HP]	3	5	7.5	10	5	7.5	10.0	15	20
	Output Current, [A]*1	9	13	25	32	9	13	17.0	25	32	
	Power Capacity, [kVA]	5.9	8.9	17	21	5.9	8.9	11	17	21	
	Overload Capacity	150% for 60 Sec & 180% for 3 Sec									
	Max. output voltage	Three-phase 200Vac to 240Vac (Proportional to input voltage)				Three-phase 380Vac to 480Vac (Proportional to input voltage)					
Max. output frequency	100 Hz										
Braking Resistor	Recommended Power, [W]	500	750	1200	1500	750	1200	1500	2500	3000	
	Recommended Resistance, [Ω]	≥ 65	≥ 45	≥ 22	≥ 16	≥ 130	≥ 90	≥ 65	≥ 43	≥ 32	
Enclosure		IP 21									

☆: At 4 kHz carrier frequency without derating.

★: The mounting dimensions are shown below.

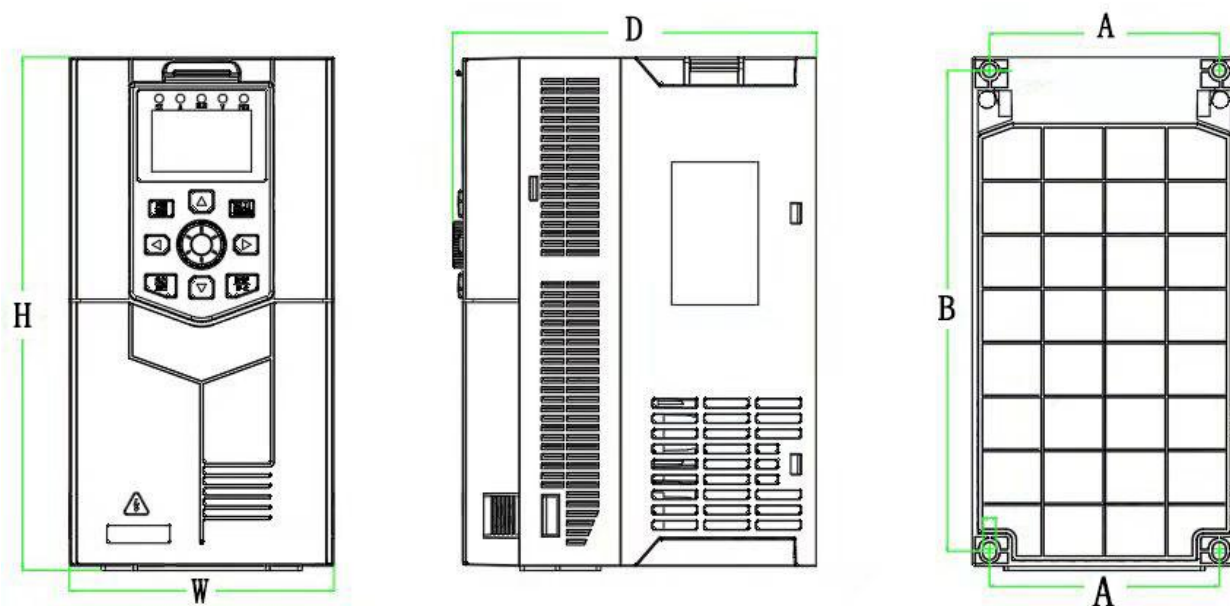

Fig 1. Physical appearance and dimensions

2 Wiring

2.1 Typical wiring 1

(Default: **F0-03=6**, use multi-reference)

Voltage class		220VAC				380/400/415VAC				
Drive Model		2T2.2GB	2T3.7GB	2T5.5GB	2T7.5GB	T3.7GB	T5.5GB	T7.5GB	T11GB	T15GB
Braking Resistor	Recommended Power, [W]	500	750	1200	1500	750	1200	1500	2500	3000
	Recommended Resistance, [Ω]	≥ 65	≥ 45	≥ 22	≥ 16	≥ 130	≥ 90	≥ 65	≥ 43	≥ 32

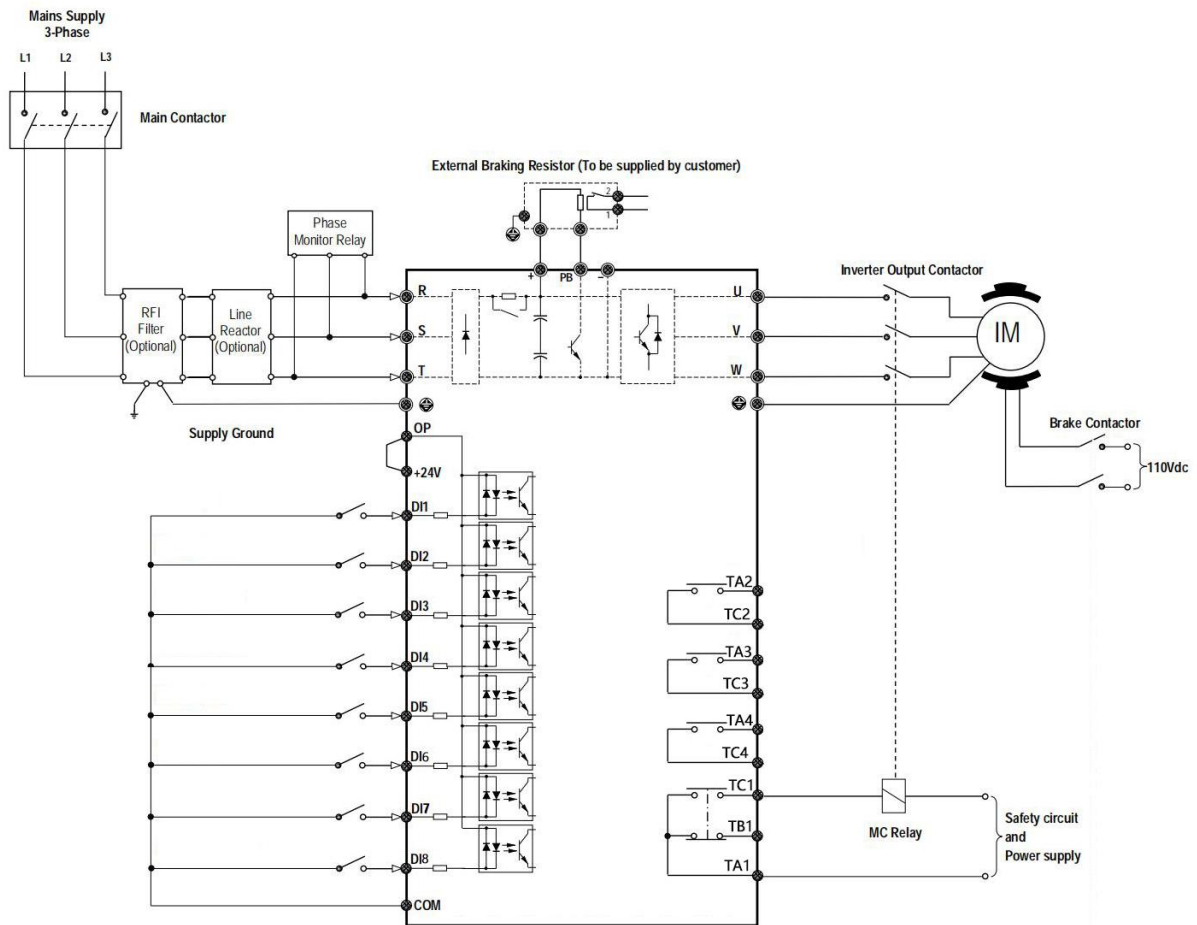

2.2 Terminal description

✓ Terminals of main circuit

Warning: Do not use terminal (-) for braking resistor, otherwise inverter would be damaged!

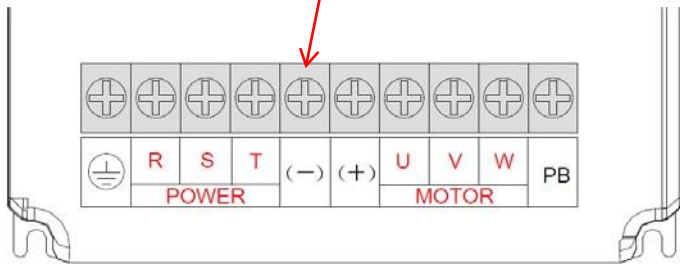

Terminal	Terminal Name	Description
R, S, T	Three-phase power supply input terminals	Connect to the three-phase AC power supply.
(-), (+)	Positive and negative terminals of DC bus	Common DC bus input point.
PB, (+)	Connecting terminals of braking resistor	Connect to a braking resistor.
U, V, W	Output terminals	Connect to a three-phase motor.
	Grounding terminal	Must be grounded.

✓ Terminals of main control board

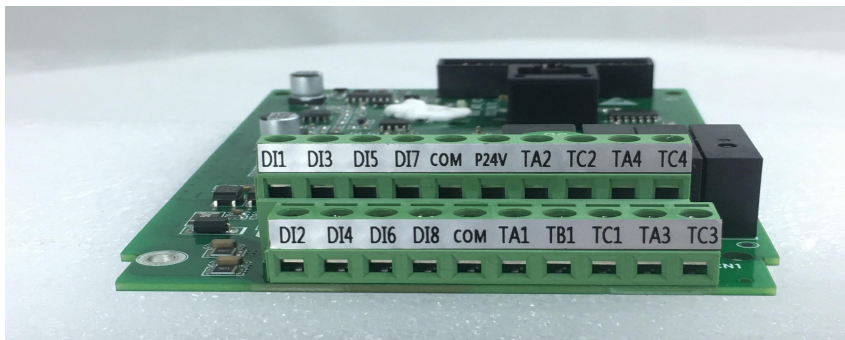

Terminal	Terminal Name	Description
P24V-COM	+24 VDC power supply	Provide +24 VDC power supply externally. Usually, it provides power supply to DI/DO terminals and external sensors. Max. output current: 200 mA.
DI1-COM	Digital input 1	
DI2-COM	Digital input 2	
DI3-COM	Digital input 3	
DI4-COM	Digital input 4	Optical coupling isolation, compatible with dual-polarity input. Impedance: 2.4 kΩ.
DI5-COM	Digital input 5	Input voltage range: 9 to 30 VDC.
DI6-COM	Digital input 6	
DI7-COM	Digital input 7	
DI8-COM	Digital input 8	
TA1-TB1	Normally closed terminal	
TA1-TC1	Normally open terminal	
TA2-TC2	Normally open terminal	Contact driving capacity: 250 VAC, 3A; 30 VDC, 1A.
TA3-TC3	Normally open terminal	
TA4-TC4	Normally open terminal	

3 Operation panel

3.1 Get familiar with operation panel



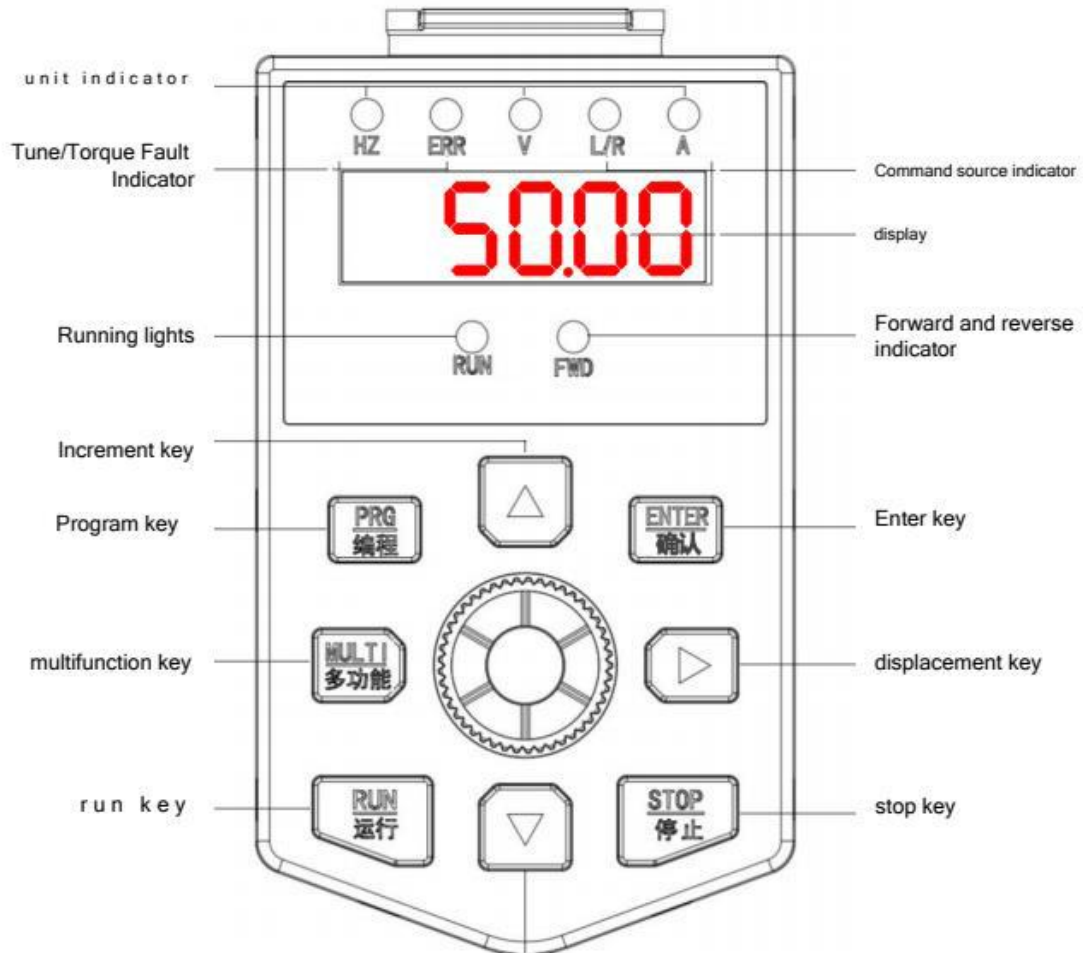





✓ Overview



✓ Parameter unit indicator

Indicator appearance	Meaning
	Hz for frequency
	A for current
	V for voltage
	% for anything relevant

✓ Keys on operation panel

Key	Key Name	Function
	Programming	Enter or exit Level I menu.
	Confirm	Enter the menu interfaces level by level, and confirm the parameter setting.
	Increment	Increase data or function code.
	Decrement	Decrease data or function code.
	Shift	Select the displayed parameters in turn in the stop or running state, and select the digit to be modified when modifying parameters.
	RUN	Start the AC drive in the keypad operation mode.
	Stop/Reset	Stop the AC drive when it is in the running state and perform the reset operation when it is in the faulty state. The functions of this key are restricted by F7-02 .
	Multifunction	Perform function switchover (such as quick switchover of command source or direction) according to the setting of F7-01 .

✓ **Relevant parameters for operation panel setting**

Function code	Parameter Name	Setting Range	Unit	Default	Commission
F7-01	MULTI function selection	0: MULTI key disabled 1: Switchover from remote control (terminal or communication) to keypad control 2: Switchover between forward rotation and reverse rotation 3: Forward jog 4: Reverse jog 5: Individualized parameter display	N.A.	0	0
F7-02	STOP/RESET key function	0: STOP/RESET key enabled only in keypad control 1: STOP/RESET key enabled in any operation mode	N.A.	1	1
FP-03	Parameter display property	For user defined and user modified parameters 00: non of them will display 01: user defined parameters will display 10: user modified parameters will display 11: both of them will display	N.A.	00	

✓ Operations of parameters

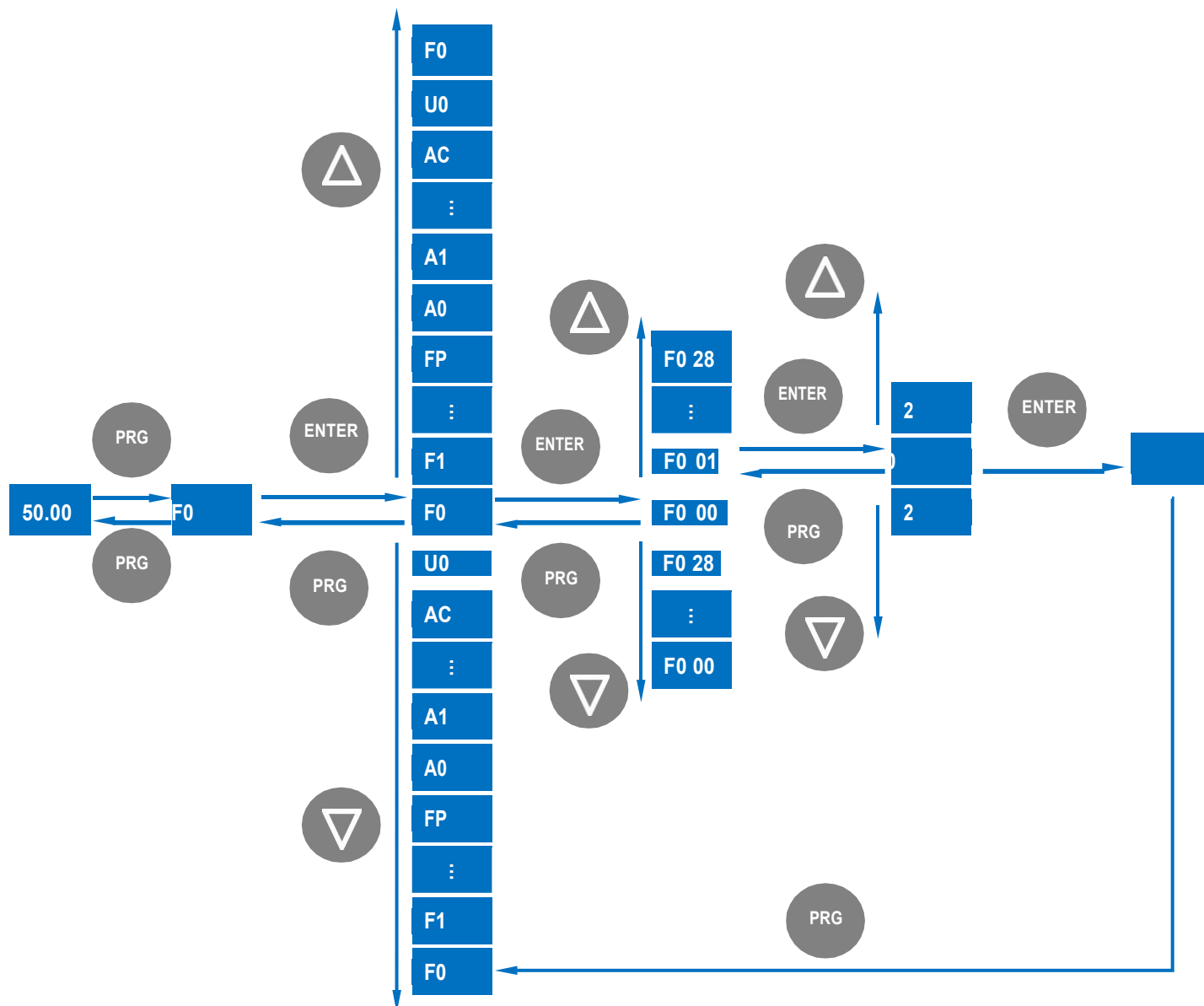

✓ Parameter arrangement

Function code Group	Description	Remark
F0 to FF	Standard function code group	Standard function parameters
A0 to AC	Advanced function code group	AI/AO correction
U0	Running state function code group	Display of state-monitoring parameters

4 Quick setup

4.1 Complete timing diagram for normal travel (use multi-reference as frequency reference)

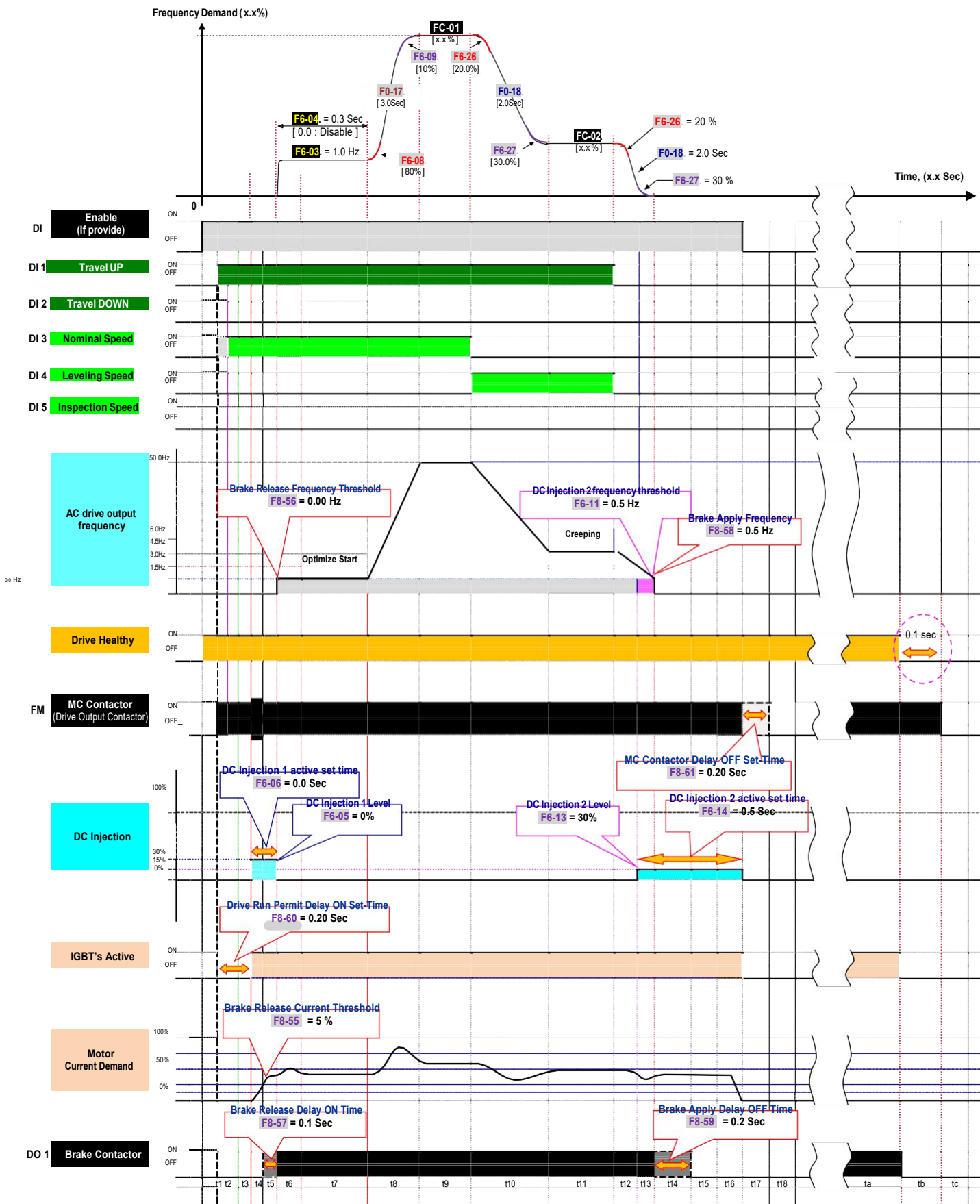

✓ **Timing diagram description**

Event	Descriptions	Function	Drive Status
ta	- Drive healthy - MC and brake Contactor are energised	----	RUN
tb	- Drive Trip - IGBTs disable - Brake contactor de-energised	----	Trip
tc	- MC contactor got de-energised provided drive IGBTs are disabled after 0.1sec	----	Trip
t1	- Drive waits to enable by lift controller	----	Inhibit
t2	- Drive MC contactor output energized when direction demand command enable by the liftcontroller. - Desired preset speed reference command enable by lift controller	F8-60	Ready
t3	- Drive IGBTs immediately go into active mode after the desire drive run permit delay ON set time has elapse.	F8-60	STOP
t4	- DC injection active - Motor brake contactor energized when motor current demand excess the brake release current level and brake release frequency	F6-05 F6-06 F8-55 F8-56	RUN
t5	- Motor brake contactor is energized - Optimize profile generator active - Motor start to run	F8-57 F6-03 F6-04	RUN
t6	- DC injection 1 disable after the desired set time has elapsed	F6-06	RUN
t7	- Start optimizer profile generator disable after the desired set time has elapse.	F6-04	RUN
t8	- Motor ramp up to the desire preset speed reference.	F6-08 F6-09 F0-17 FC-0x	RUN
t9	- Drive output at speed status	FC-0x	RUN
t10	- Change of preset speed reference demand - Motor ramp down to the desire preset speed reference	F6-08 F6-09 F0-17 FC-0x	RUN
t11	- Drive output at speed status	FC-0x	RUN
t12	- Direction demand command disabled - Motor ramp down to zero speed	F6-08 F6-09 F0-18	RUN
t13	- DC injection active when drive output falls below the DC injection 2 frequency threshold	F6-11 F6-13	RUN
t14	- Brake contactor got de-energise when the drive output frequency fall below the brake apply frequency	F8-56 F8-59	RUN
t15	- DC injection still active when brake contactor got de-energise.	F6-13	RUN
t16	- DC injection disable after the desire set time has elapse	F6-14	STOP
t17	- Drive IGBTs got disable - MC contactor delay OFF time active	----	Ready
t18	- MC contactor de-energise after the desire set time has elapse	F8-61	Inhibit

4.2 Elevator performance fine tuning

Frequency Demand

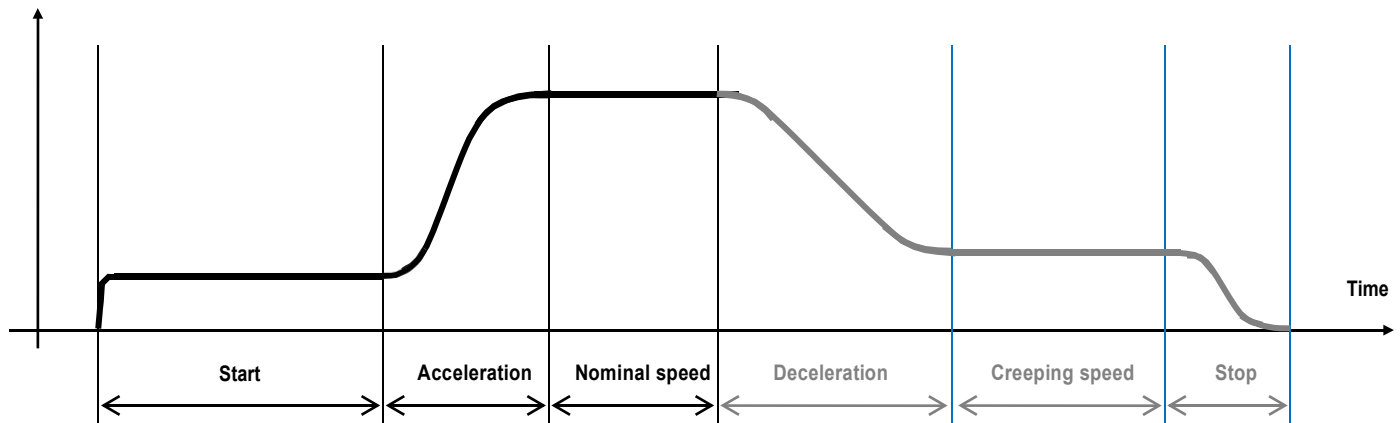

Stage	Symptom	Diagnostics	Remedies
Start	Rollback	Brake device releases too early	Increase F8-57 , ranging 0 to 0.5s
		Start frequency is too low	Increase F6-03 , ranging 0 to 1.5Hz
		Torque output is insufficient	Make sure F3-00=0 , F3-01=0
	Starting jerk	Brake device releases too late	Decrease F8-57 , ranging 0 to 0.5s
		Start frequency is too high	Decrease F6-03 , ranging 0 to 1.5Hz
Acceleration	Jerk when acceleration starts	Too fast acceleration at this section	Increase F6-08 , ranging 0 to 80% ; Or increase F0-17 , ranging 0 to 20s
	Jerk when acceleration end	Too fast acceleration at this section	Increase F6-09 , ranging 0 to (95-(F6-08))% Or increase F0-17 , ranging 0 to 20s
	Overshoot when acceleration ends	Too big speed loop PI gains	Decrease F2-03 , ranging 0 to 100 Or increase F2-04 , ranging 0 to 10
	Vibration	Toosmall margin between F2-02 and F2-05	Make sure F2-05 - F2-02 > 3Hz , usually increase F2-05 , ranging from F2-02 to 7Hz
		Overcurrent stall prevention occurs	Make sure F3-18=170%
Nominal speed	Vibration	Too big speed loop PI gains	Decrease F2-00 or F2-03 , ranging 0 to 100 ; Or increase F2-01 or F2-04 , ranging 0.01 to 10.00
		Too big current loop PI gains	Double check the motor parameters and then perform motor auto-tuning once more

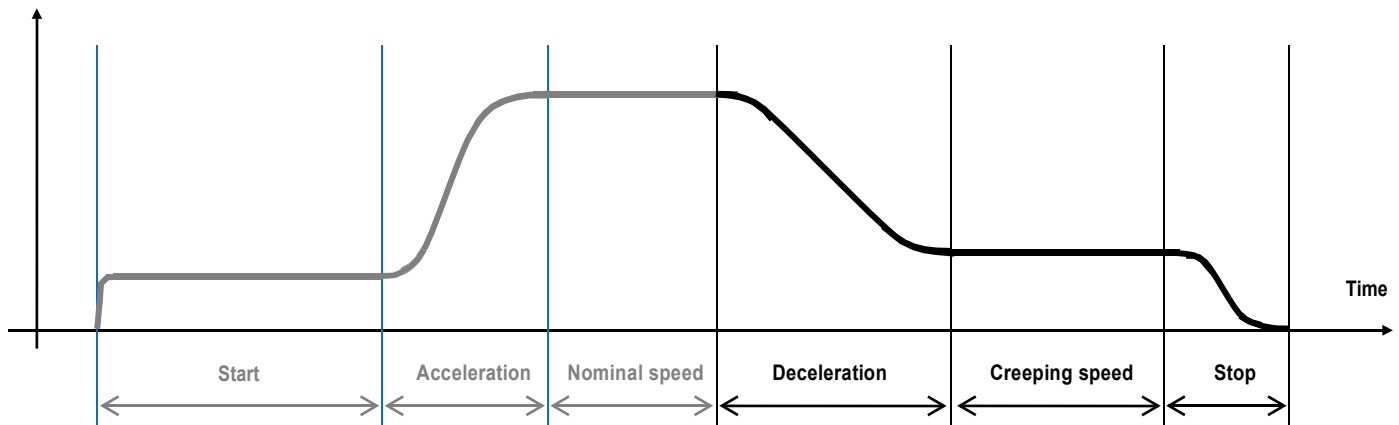

Stage	Symptom	Diagnostics	Remedies
Deceleration	Jerk when deceleration starts	Too fast deceleration at this section	Increase F6-26 , ranging 0 to 80% ; Or increase F0-18 , ranging 0 to 20s
	Vibration	Overcurrent stall prevention occurs	Make sure F3-18=170%
	Jerk when deceleration ends	Too fast deceleration at this section	Increase F6-27 , ranging 0 to 80% ; Or increase F0-18 , ranging 0 to 20s
Creeping speed	Vibration	Torque output is insufficient	Make sure F3-00=0 , F3-01=0
	Elevator gets stuck	Torque output is insufficient	Make sure F3-00=0 , F3-01=0
	Move much slower than expected	Torque output is insufficient Too small creeping speed setting	Make sure F3-00=0 , F3-01=0 Increase F4-16 , ranging 0 to 100% ; Or decrease relevant multi-reference
Stop	Jerk	Too fast deceleration at this section	1. Increase F6-27 , ranging 0 to 80% ; Or increase F0-18 , ranging 0 to 20s ; 2. Use second deceleration time F8-04 : First, set F8-04 bigger than F0-18 , ranging F0-18 to 20s ; then set F8-26 = creeping speed
		Braking device applies too early	Make sure F8-58=0.5Hz , then increase F8-59 , ranging 0 to 0.5s
		Too strong DC injection at stop	Decrease F6-13 , ranging 0 to 100%
	Slip	Too short DC injection active time at stop	Increase F6-14 , ranging 0 to 1s
		Too weak DC injection at stop	Increase F6-13 , ranging 0 to 100%
		Braking device applies too late	Make sure F8-58=0.5Hz , then decrease F8-59 , ranging 0 to 0.5s
	Inaccurate levelling position	Too slow deceleration	1. If F8-04 is not applied, then decrease F0-18 , ranging 0 to 20s ; 2. If F8-04 is applied, then firstly decrease F8-04 , ranging F0-18 to 20s ; secondly set F8-26 = creeping speed
		Slip occurs	Refer to problem 'Slip'
	Levelling varies with different loads	Too weak slip compensation	For SVC, increase F2-06 or F2-00 ; For VF, increase F3-09

4.3 Setup flowchart

START

Ahead of setup

Remove DI wirings

Restore parameters

Set motor parameters

CONTINUE

CONTINUE

Para	Parameter name	Default	Commissioning
------	----------------	---------	---------------

Default values are elicited from enormous real elevator applications, so users can rely on them usually, only some adjustments are necessary.
If parameter restoration is prohibited due to some reasons, then the following steps have to be followed one by one.

usually if any DI is set as Forward or Reverse run and if signal is active, then some operations cannot succeed, such as restoring parameters, changing command source, which are necessary steps for quick setup. So it's seriously recommended to remove DI wirings at the beginning of commissioning.

FP-01	Parameter operation	0	1
	0: No operation 1: Restore default settings except motor parameters 2: Clear records including errors 4: Restore user's backup parameters 501: Backup parameters NOTE: usually people have no idea what parameters have been changed, so it's seriously recommended to restore parameters to default at the beginning of commissioning.		

Motor Nameplate

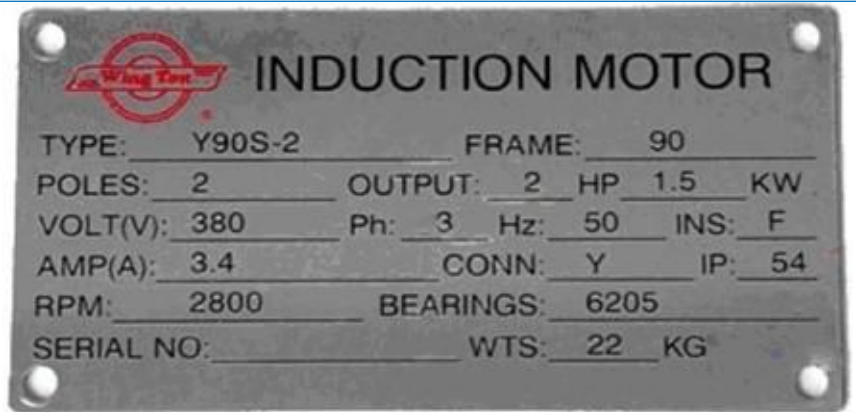



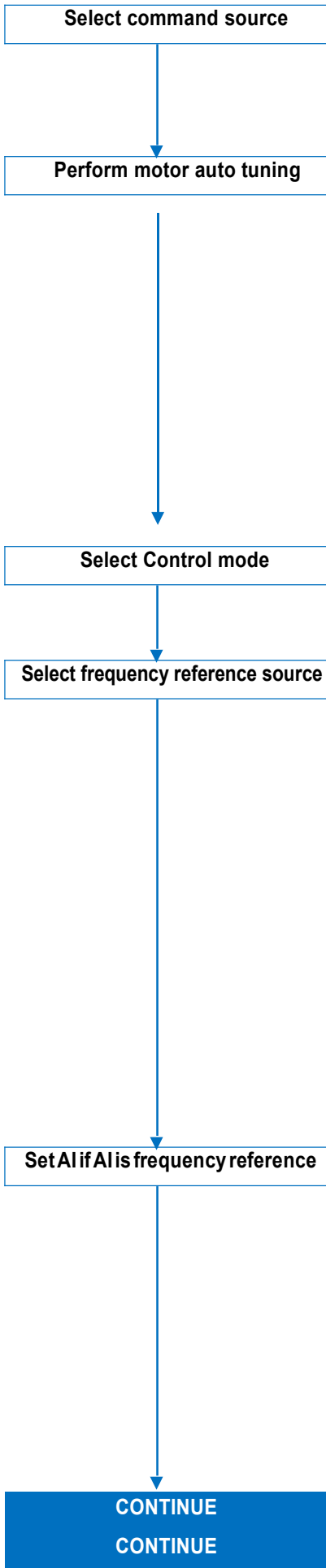

F1-01	Rated motor power	model dependent	
	Unit: kW		
F1-02	Rated motor voltage	400	
	Unit: V		
F1-03	Rated motor current	model dependent	
	Unit: A		
F1-04	Rated motor frequency	50.00	
	Unit: Hz		
F1-05	Rated motor speed	1440	
	Unit: rpm.		

Para.	Parameter name	Default	Commissioning
-------	----------------	---------	---------------

Para.	Parameter name	Default	Commissioning
-------	----------------	---------	---------------



F0-02	Command source selection	1	0
	0: Operation panel control (indicator 'LOCAL/REMOT' OFF) 1: Terminal control (indicator 'LOCAL/REMOT' ON) 2: Communication control (indicator 'LOCAL/REMOT' blinking)		
F1-37	Auto-tuning selection	0	3
	0: No auto-tuning 2: Asynchronous motor dynamic auto-tuning 3: Asynchronous motor static auto-tuning(NEW) NOTE: Motor won't rotate at this stage. Steps of auto-tuning: 1. Make sure the UVW connection between AC drive and motor is not cut off by output contactor; if it is cut off, then manually handle with the output contactor; 3. Set F1-37=3, press ENTER , then LED on panel will display letters 'TUNE'; 4. Press the key RUN on panel, then motor starts auto-tuning, it usually takes about 30 seconds to finish this auto-tuning, wait until LED stops displaying 'TUNE'; 5. Restore F0-02 to the default value 1.		
F0-01	Control mode selection	2	0 or 2
	0: SVC control 2: VF control		
F0-03	Main frequency source X selection	6	2 or 6
	0: Digital setting F0-08 (pressing  or  can change F0-08 easily, and the changed value won't be cleared even after power off) 1: Digital setting F0-08 (pressing  or  can change F0-08 easily, but changed value would be cleared after power off) 2: AI1 3: AI2 4: AI3 5: Pulse setting (DI5) 6: Multi-reference setting 7: Simple PLC 8: PID 9: Communication setting		
F4-13	AI curve 1 minimum input	0.00	0.00
	0 V to F4-15;		
F4-14	Corresponding setting of AI1 minimum input	0.0	0.0
	-100.0% to 100.0%		
F4-15	AI1 maximum input	5.00	
	F4-13 to 10.00 V		
F4-16	Corresponding setting of AI1 maximum input	100.0	
	-100.0% to 100.0%		

Para.	Parameter name	Default	Commissioning
Para.	Parameter name	Default	Commissioning

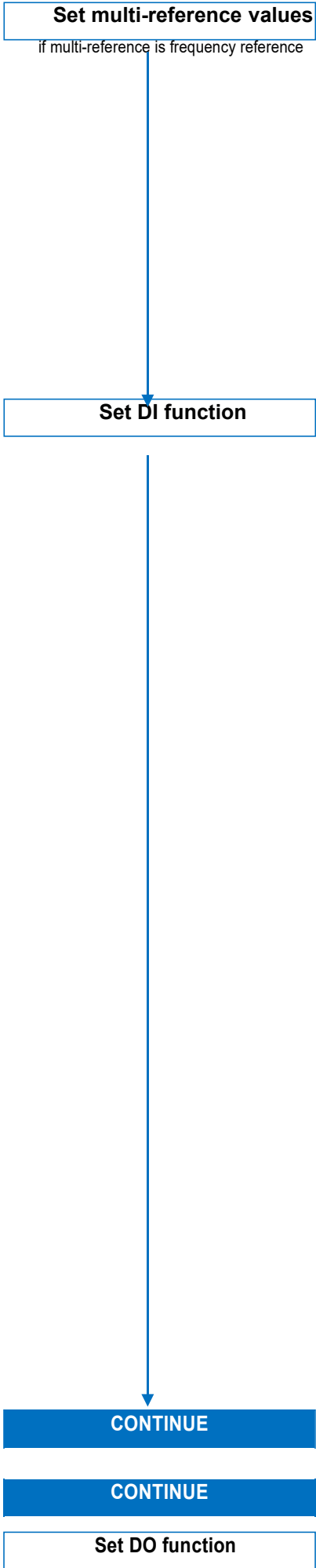

FC-01	Reference 1	100.0	100.00
	0.0 to 100.0%. NOTE : FC-01 is set as nominal speed of elevator.		
FC-02	Reference 1	11.0	11.0
	0.0 to 100.0%. NOTE : FC-02 is set as creep speed of elevator.		
FC-04	Reference 4	40.0	40.00
	0.0 to 100.0%. NOTE : FC-04 is set as inspection speed of elevator.		
FC-08	Reference 8	20.0	20.0
	0.0 to 100.0%. NOTE : FC-08 is set as ARD speed of elevator.		
F4-00	DI1 function selection	1	1 (Forward run)
	0: No function 1: Forward RUN (FWD) 2: Reverse RUN (REV) 8: IGBT Enable 9: Fault reset (RESET) 12: Multi-reference terminal 1 13: Multi-reference terminal 2 14: Multi-reference terminal 3 Setting range:0 to 59; NOTE : this signal comes from elevator controller.		
F4-01	DI2 function selection	2	2 (Reverse run)
	Setting range same as DI1; NOTE : this signal comes from elevator controller.		
F4-02	DI3 function selection	12	12
	Setting range same as DI1 NOTE : if analog input is used as frequency reference, then DI3 is useless, just leave it alone. If multi-reference is used as frequency reference, then signal 'nominal speed' comes from elevator controller.		
F4-03	DI4 function selection	13	13
	Setting range same as DI1. NOTE : if analog input is used as frequency reference, then DI4 is useless, just leave it alone. If multi-reference is used as frequency reference, then signal 'creep speed' comes from elevator controller.		
F4-04	DI5 function selection	14	14
	setting range same as DI1; NOTE : if analog input is used as frequency reference, then DI5 is useless, just leave it alone. If multi-reference is used as frequency reference, then signal 'inspection speed' comes from elevator controller.		
F4-05	DI6 function selection	0	
	setting range same as DI1;		

Para.	Parameter name	Default	Commissioning
-------	----------------	---------	---------------

Para.	Parameter name	Default	Commissioning
-------	----------------	---------	---------------

F5-01	FM function selection	2	2(Fault output)
--------------	-----------------------	---	-----------------

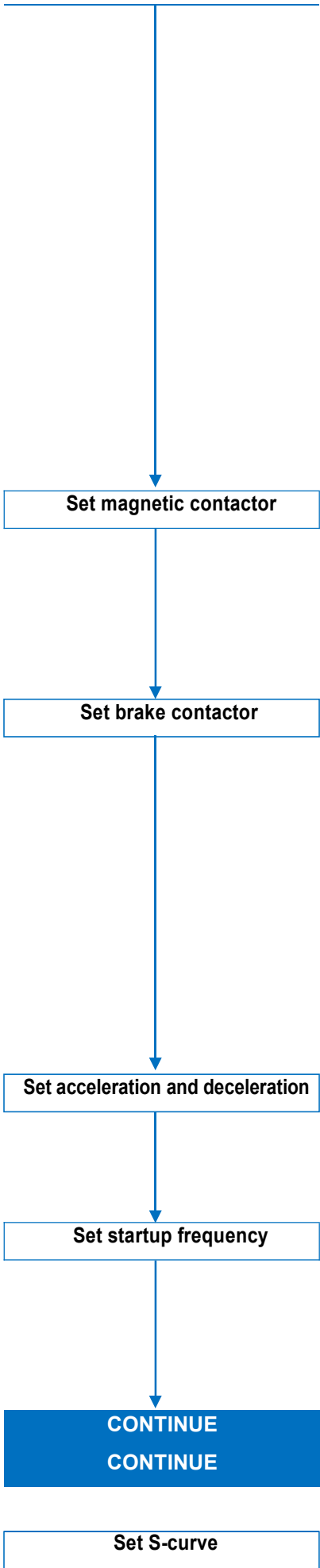

	0 : No output 1 : AC drive running 2 : Fault output 36: Software current exceeding limit 42 : Brake output 43 : MC (Magnetic contactor) output Setting range:0 to 59; NOTE : this signal goes to magnetic contactor.		
F5-02	Relay function selection(TA/TB/TC)	43	43 (MC)
	Setting range same as FM; NOTE : this signal goes to magnetic controller.		
F5-03	Relay function selection(PA/PB/PC)	42	42(Brake)
	Setting range same as FM; NOTE : this signal goes to brake contactor.		
F8-60	Drive run delay ON set time	0.20	0.20
	0.00 to 10.00 Sec; NOTE : if MC is controlled by elevator controller, then F8-60 is useless.		
F8-61	MC contactor delay OFF set time	0.20	0.20
	0.00 to 10.00 Sec; NOTE : if MC is controlled by elevator controller, then F8-61 is useless.		
F8-55	Brake release current threshold	5	5
	0 to 200%;		
F8-56	Brake release frequency threshold	0.00	0.0
	0.00 to 25.00 Hz;		
F8-57	Brake release delay ON set time	0.0	0.0
	0.0 to 5.0 Sec;		
F8-58	Brake apply frequency threshold	0.5	0.5
	0.00 to 25.00 Hz;		
F8-59	Brake apply delay OFF set time	0.2	0.2
	0.0 to 5.0 Sec;		
F0-17	Acceleration time 1	3.0	3.0
	0.0 to 6500.0 sec.		
F0-18	Deceleration time 1	2.0	2.0
	0.0 to 6500.0 sec.		
F6-03	Startup frequency	1.0	1.0
	0.0 to 10.0 Hz;		
F6-04	Startup frequency active set time	0.3	0.3
	0.0 to 100.0 Sec		

Para.	Parameter name	Default	Commissioning
Para.	Parameter name	Default	Commissioning

F6-07	Acceleration/Deceleration mode	3	3
	0 : Linear acceleration/ deceleration 3: S-curve acceleration/ deceleration C		

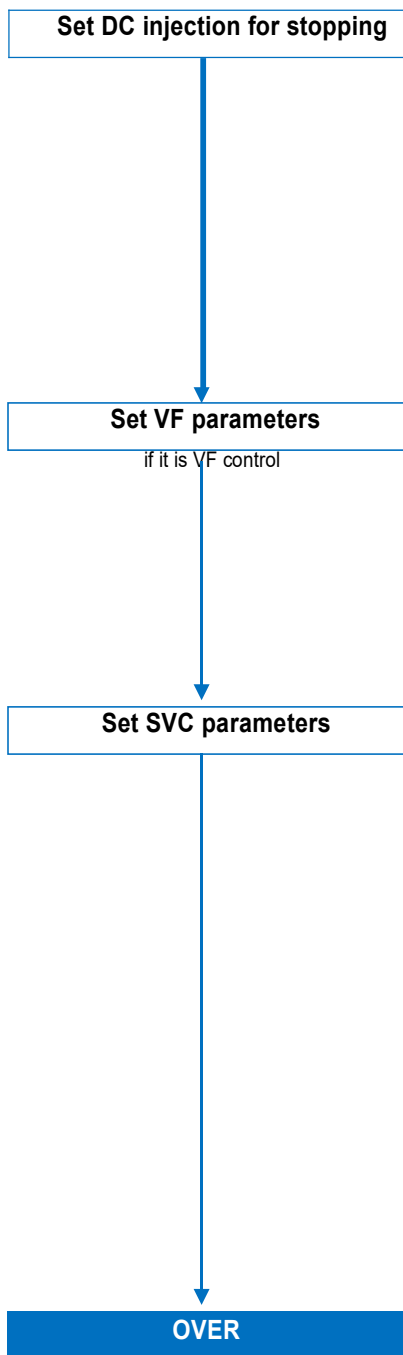

F6-08	Time proportion of S-curve at Accel start	80.0	80.0
	0.0% to Min[(100.0% - F6-09), 80%]		
F6-09	Time proportion of S-curve at Accel end	10.0	10.0
	0.0% to Min[(100.0% - F6-08), 80%]		
F6-26	Time proportion of S-curve at Decel start	20.0	20.0
	0.0% to Min[(100.0% - F6-27), 80%]		
F6-27	Time proportion of S-curve at Decel end	30.0	30.0
	0.0% to Min[(100.0% - F6-26), 80%]		
F6-11	DC injection 2 frequency threshold	0.50	0.50
	0.00 Hz to maximum frequency		
F6-12	DC Injection 2 delay ON set time	0.0	0.0
	0.0 to 36.0 Sec		
F6-13	DC injection 2 level	30	30
	0 to 100 Hz		
F6-14	DC injection 2 active set time	0.5	0.5
	0.0 to 36.0 Sec		
F3-00	V/F curve selection	0	0
	0: Linear V/F 1: Multi-point V/F SETTING RANGE: 0 to 11;		
F3-01	Torque boost	0.0	0.0
	0.0 to 30.0 %; NOTE: if it is 0, then auto torque boost is activated, and it is recommended to use auto torque boost.		
F2-00	Speed loop proportional gain 1	10	10
	0 to 100.		
F2-01	Speed loop integral time 1	0.5	0.5
	0.01 to 10.00 Sec.		
F2-02	Switchover frequency 1	3.00	3.00
	0.00 to F2-05		
F2-03	Speed loop proportional gain 2	30	30
	0 to 100.		
F2-04	Speed loop integral time 2	0.5	0.5
	0.01 to 10.00 Sec.		
F2-05	Switchover frequency 2	7.00	7.00
	F2-02 to maximum output frequency		

4.4 IGBT Enable

In all elevator applications, an Output Contactor is installed between the AC drive output U, V, W and the motor. In an emergency, the Safety Line is opened due to an unsafe condition and the Output Contactor disconnects the power from the inverter to the motor (the motor brake is also applied at the same time). When the Output Contactor opens with current flowing through to the motor (inverter IGBTs are active), there will be arcing in the Output Contactor depending on the motor inductive energy. Arcing of the Output Contactor can reduce the lifetime of the contactor and in some severe cases can damage the contacts poles. Therefore it is recommended to electronically switch off the AC drive IGBT firing circuits before opening the Output Contactor (milliseconds later). The AC drive IGBT firing can be electronically switched off with the

"IGBT Enable" function as shown in the timing charts below.

CAUTION: An Output Contactor MUST always be installed as the final safety power cut off to the motor. The "IGBT Enable" function is NOT a substitute for an Output Contactor, it is designed to work together with the Output Contactor.

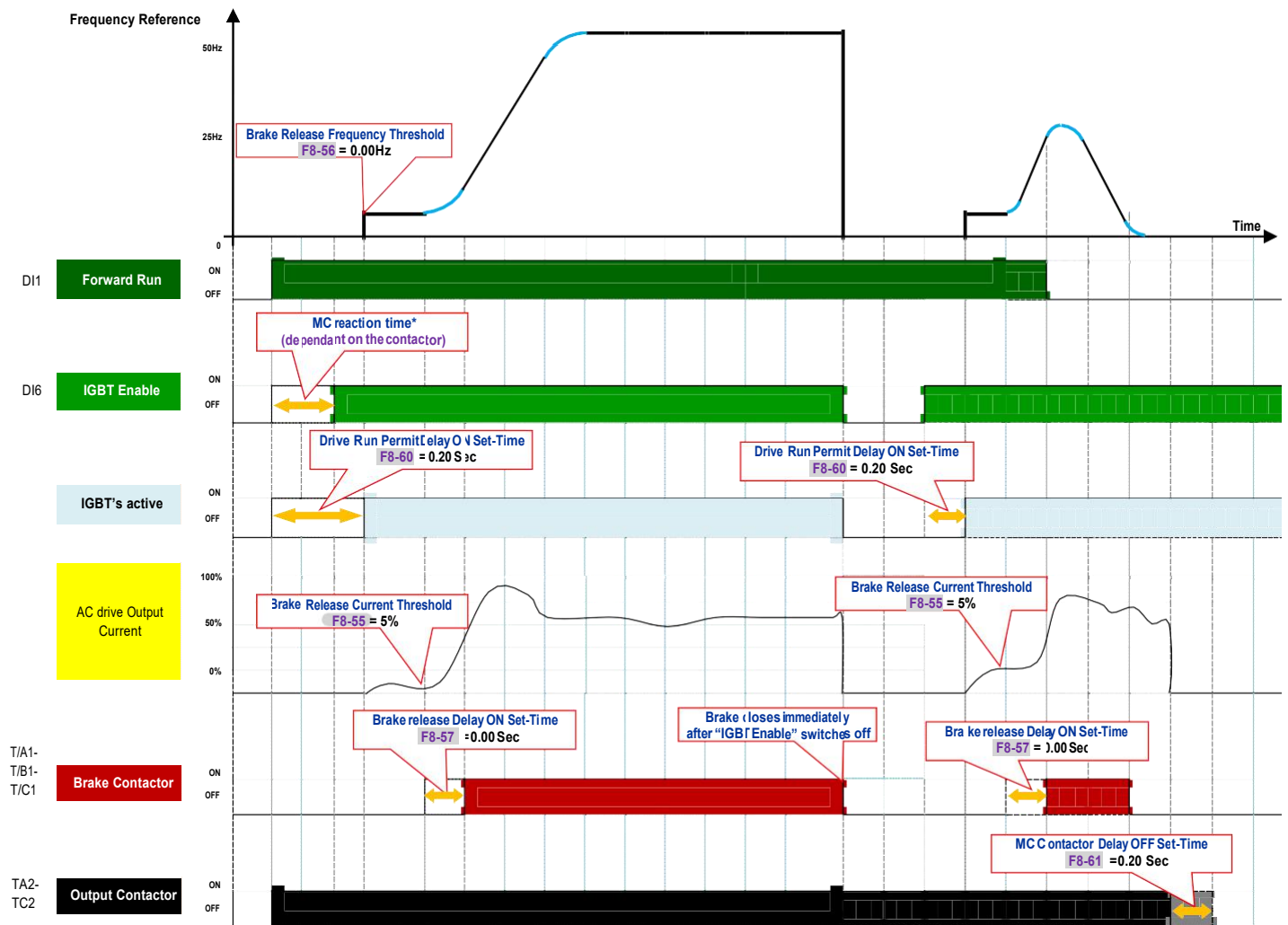

* MC reaction time: the reaction time of output relay of MC.

For some applications, the status of output contactor needs to be checked before AC drive starts up, hence one relay output of MC will feedback to IGBT Enable (above in the diagram it is D16).

This function can work by assigning “IGBT Enable” function to a digital input, please refer to the table below to set.
 Take DI6 for example: assign “IGBT Enable” to DI6, then set F4-05=8. If it’s necessary to change active mode of IGBT Enable, then use F4-38 or F4-39 to set (low level or high level active).

Function Code	Parameter Name	Setting Range	Unit	Default	Commission
F4-00	DI 1 function selection	0 : No function	N.A	1	
F4-01	DI 2 function selection	1 : Forward RUN (FWD)	N.A	2	
F4-02	DI 3 function selection	2 : Reverse RUN (REV)	N.A	12	
F4-03	DI4 function selection	N.A	13	
F4-04	DI5 function selection	8 : IGBT Enable	N.A	14	
F4-05	DI6 function selection	N.A	0	8
F4-06	DI7 function selection	12: Multi-reference terminal 1	N.A	15	
F4-07	DI8 function selection	13: Multi-reference terminal 2	N.A	0	
		14: Multi-reference terminal 3			
		15: Multi-reference terminal 4			
				
F4-38	DI active mode selection (Normal: low level active)	7-segment	0 0 0 0 0	N.A	00000
	DI5 active mode: 0: Normal 1: Opposite		↑		
	DI4 active mode: 0: Normal 1: Opposite		↑		
	DI3 active mode: 0: Normal 1: Opposite		↑		
	DI2 active mode: 0: Normal 1: Opposite		↑		
	DI1 active mode: 0: Normal 1: Opposite		↑		
F4-39	DI active mode selection 2 (Normal: low level active)	7-segment	0 0 0	N.A	00000
	DI8 active mode: 0: Normal 1: Opposite		↑		
	DI7 active mode: 0: Normal 1: Opposite		↑		
	DI6 active mode: 0: Normal 1: Opposite		↑		

5 Function code table

NOTE: not all parameters are listed, here below are relevant to open loop elevator applications.

5.1 Group F0: fundamental

Function Code	Parameter name	Setting Range	Unit	Default	Commission
F0-01	Motor 1 control mode	0 : Sensor-less flux vector control (SFVC) 2 : V/F control	N.A	2	
F0-02	Command source selection	0 : Operation panel control (LED off) 1 : Terminal control (LED on) 2 : Communication control (LED flashing)	N.A	1	
F0-03	Main frequency source X selection	2: AI-1 3: AI-2 4: AI-3 6 : Multi-reference	N.A	6	
F0-07	Frequency source selection	0 : Main frequency source X	N.A	0	
F0-09	Rotation direction	0: Same direction 1: Reverse direction	N.A	0	
F0-10	Maximum frequency	50.00 to 100.00	Hz	50.00	
F0-15	Carrier frequency	0.5 to 11.0 (SVC mode: 0.5 to 9) (VF mode: 0.5 to 11)	kHz	Model dependant	
F0-17	Acceleration time 1	0.00 to 650.00 (F0-19 = 2) 0.0 to 6500.0 (F0-19 = 1) 0 to 65000 (F0-19 = 0)	Sec	3.0	
F0-18	Deceleration time 1	0.00 to 650.00 (F0-19 = 2) 0.0 to 6500.0 (F0-19 = 1) 0 to 65000 (F0-19 = 0)	Sec	2.0	
F0-19	Acceleration/Deceleration time unit	0 : 1 1 : 0.1 2 : 0.01	Sec	1	1

5.2 Group F1: motor 1 parameters

Function Code	Parameter name	Setting Range	Unit	Default	Commission
F1-00	Motor type selection	0 : Common asynchronous motor 1 : Variable frequency asynchronous motor	N.A	0	
F1-01	Motor rated power	0.1 to 1000.0	kW	Model dependent	
F1-02	Motor rated voltage	1 to 2000	V	400	
F1-03	Motor rated current	0.01 to 655.35 (For AC drive power ≤ 55 kW) 0.1 to 6553.5 (For AC drive power > 55 kW)	A	Model dependent	
F1-04	Motor rated frequency	0.01 Hz to maximum frequency	Hz	50	
F1-05	Motor rated rotational speed	1 to 65535	RPM	1440	
F1-06	Stator resistance (asynchronous motor)	0.001 to 65.535 (AC drive power ≤ 55 kW) 0.0001 to 6.5535 (AC drive power > 55 kW)	Ω	0	
F1-07	Rotor resistance (asynchronous motor)	0.001 to 65.535 (AC drive power ≤ 55 kW) 0.0001 to 6.5535 (AC drive power > 55 kW)	Ω	0.000	
F1-08	Leakage inductive reactance (asynchronous motor)	0.01 to 655.35 mH (AC drive power ≤ 55 kW) 0.001 to 65.535 (AC drive power > 55 kW)	mH	0.00	
F1-09	Mutual inductive reactance (asynchronous motor)	0.01 to 655.35 (AC drive power ≤ 55 kW) 0.001 to 65.535 (AC drive power > 55 kW)	mH	0.00	
F1-10	No-load current (asynchronous motor)	0.01 to F1-03 (AC drive power ≤ 55 kW) 0.1 to F1-03 (AC drive power > 55 kW)	A	0.00	
F1-37	Auto tuning selection	0 : No auto-tuning 2: Asynchronous motor dynamic auto-tuning 3 : Asynchronous motor static auto-tuning(NEW)	N.A	0	

5.3 Group F2: vector control

Function Code	Parameter name	Setting Range	Unit	Default	Commission
F2-00	Speed loop proportional gain 1	0 to 100	N.A	10	
F2-01	Speed loop integral time 1	0.01 to 10.00	Sec	0.50	
F2-02	Switchover frequency 1	0.00 to F2-05	Hz	3.00	
F2-03	Speed loop proportional gain 2	0 to 100	N.A	30	
F2-04	Speed loop integral time 2	0.01 to 10.00	Sec	0.5	
F2-05	Switchover frequency 2	F2-02 to maximum output frequency	Hz	7.00	
F2-06	SVC slip gain	50 to 200	%	100	
F2-10	Torque upper limit (for SVC)	0.0 to 200.0 (% AC drive rated current)	%	150.0	
F2-13	Excitation adjustment proportional gain	0 to 20000	N.A	2000	
F2-14	Excitation adjustment integral gain	0 to 20000	N.A	1300	
F2-15	Torque adjustment proportional gain	0 to 20000	N.A	2000	
F2-16	Torque adjustment integral gain	0 to 20000	N.A	1300	

5.4 Group F3: VF control

Function code	Parameter Name	Setting Range	Unit	Default	Commission
F3-00	V/F curve setting	0: Linear V/F 1: Multi-point V/F 2 to 11: not relevant settings	N.A.	0	
F3-01	Torque boost	0.0 to 30.0 (if it is 0, then auto torque boost is activated)	%	0	
F3-02	Cut-off frequency of torque boost	0.00 to max output frequency	Hz	50.00	
F3-03	Multi-point V/F frequency 1 (F1)	0.00 to F3-05	Hz	1.50	
F3-04	Multi-point V/F voltage 1 (V1)	0.0 to 100.0	%	6.0	
F3-05	Multi-point V/F frequency 2 (F2)	F3-03 to F3-07	Hz	3.00	
F3-06	Multi-point V/F voltage 2 (V2)	0.0 to 100.0	%	8.0	
F3-07	Multi-point V/F frequency 3 (F3)	F3-05 to rated motor frequency (F1-04)	Hz	8.00	
F3-08	Multi-point V/F voltage 3 (V3)	0.0 to 100.0	%	20.0	
F3-09	V/F slip compensation gain	0 to 200.0	%	0.0	
F3-10	V/F over-excitation gain	0 to 200	%	0	
F3-11	V/F oscillation suppression gain	0 to 100	%	30	
F3-13	Voltage source for V/F separation	0 to 8	N.A.	0	
F3-14	Voltage digital setting for V/F separation	0 to rated motor voltage	V	0	
F3-15	Voltage rise time of V/F separation	0.0 to 1000.0	s	0.0	
F3-18	Overcurrent stall prevention current limit (for VF mode)	100 to 200 (% AC drive rated current)	%	170	
F3-19	Overcurrent stall prevention enable (for VF mode)	0: Disable; 1: Enable	N.A.	1	
F3-20	Overcurrent stall prevention gain (for VF mode)	0 to 100	N.A.	20	
F3-22	Overvoltage stall prevention voltage limit (for VF/SVC)	650 to 800	V	770	
F3-23	Overvoltage stall prevention enable (for VF/SVC)	0: Disable ; 1: Enable	N.A.	0	
F3-24	Overvoltage stall prevention frequency gain (for VF/SVC)	0 to 100	N.A.	30	
F3-25	Overvoltage stall prevention voltage gain (for VF/SVC)	0 to 100	N.A.	30	

5.5 Group F4: input terminals

Function Code	Parameter name	Setting Range	Unit	Default	Commission
F4-00	DI 1 function selection (Standard on-board)	0 : No function 1 : Forward RUN (FWD) 2 : Reverse RUN (REV) 3: Three-line Control	N.A	1	
F4-01	DI 2 function selection (Standard on-board)	4 : Jog Forward (FJOG) 5 : Jog Reverse (RJOG) 6 : TerminalUP 7 : Terminal DOWN	N.A	2	
F4-02	DI 3 function selection (Standard on-board)	8 : IGBT Enable 9 : Fault reset (RESET) 10: RUN Pause 11: Normally open (NO) input of external fault	N.A	12	
F4-03	DI 4 function selection (Standard on-board)	12: Multi-reference terminal 1 13: Multi-reference terminal 2 14: Multi-reference terminal 3 15: Multi-reference terminal 4	N.A	13	
F4-04	DI 5 function selection (Standard on-board)	16: Terminal 1 for acceleration/deceleration time selection 17: Terminal 2 for acceleration/deceleration time selection	N.A	14	
F4-05	DI 6 function selection (Standard on-board)	18: Frequency source switchover 19: UP and DOWN setting clear (terminal, operation panel) 20: Command source switchover terminal 1 21: Acceleration/Deceleration prohibited	N.A	0	8
F4-06	DI 7 function selection (Standard on-board)	22: PID pause 23: PLC status reset 24: Swing pause 25: Counter input	N.A	0	15
F4-07	DI 8 function selection (Standard on-board)	26: Counter reset 27: Length count input 28: Length reset 29: Torque control prohibited 30: Pulse input (enabled only for DI5) 31: Reserved 32: Immediate DC braking 33: Normally closed (NC) input of external fault	N.A	0	
		34: Frequency modification forbidden 35: Reverse PID action direction 36: External STOP terminal 1 37: Command source switchover terminal 2 38: PID integral pause 39: Switchover between main frequency source X and preset frequency 40: Switchover between auxiliary frequency source Y and preset frequency 41: Motor selection terminal 1 42: Motor selection terminal 2 43: PID parameter switchover	N.A	0	

Function Code	Parameter name	Setting Range	Unit	Default	Commission
		44: User defined fault 1 45: User defined fault 2 46: Speed control/Torque control switchover 47: Emergency stop 48: External STOP terminal 2 49: Deceleration DC braking 50: Clear the current running time 51: Switchover between two-line mode and three line mode 52 to 59 : Reserved			
F4-10	DI filter time	0.000 to 1.000	Sec	0.010	
F4-11	Terminal command mode	0 : Two-line mode 1 1 : Two-line mode 2 2 : Three-line mode 1 3 : Three-line mode 2	N.A	0	
F4-12	Terminal UP/DOWN rate	0.01 to 65.535	Hz/s	1.00	
F4-13	AI curve 1 minimum input	0.00 to F4-15	V	0.00	
F4-14	Corresponding setting of AI curve 1 minimum input	-100.00 to 100.00	%	0.0	
F4-15	AI curve 1 maximum input	F4-13 to 10.00V	Volt	5.00	
F4-16	Corresponding setting of AI curve 1 maximum input	-100.00 to 100.00	%	100.0	
F4-17	AI 1 filter time	0.00 to 10.00	Sec	0.10	
F4-38	DI valid mode selection (for DI1 to DI5)	00000 to 11111 (binary)	N.A	00000	
F4-39	DI valid mode selection 2 (for DI6 to DI8)	00000 to 11111 (binary)	N.A	00000	

5.6 Group F5: output terminals

Function Code	Parameter name	Setting Range	Unit	Default	Commission
F5-00	FM terminal output mode	0 : High-speed pulse output (FMP) 1 : ON/OFF output (FMR)	N.A	1	
F5-01	FMR function (open-collector output terminal) Attention! Set F5-00 = 1 when FM is used as MC or Brake output.	0 : No output 1 : AC Drive running 2 : Fault output (stop) 3 : Frequency-level detection FDT1 output 4 : Frequency reached 5 : Zero-speed running (no output at stop) 6 : Motor overload pre-warning 7 : AC Drive overload pre-warning 8 : Set count value reached	N.A	2	
F5-02	Relay function (T/A1-T/B1-T/C1)	9 : Designated count value reached 10 : Length reached 11 : PLC cycle complete 12 : Accumulated running time reached 13 : Frequency limited 14 : Torque limited 15 : Ready for RUN	N.A	43	
F5-03	Relay function (T/A2-T/C2)	16 : AI-1 larger than AI-2 17 : Frequency upper limit reached 18 : Frequency lower limit reached (no output at stop) 19 : Under-voltage state output 20 : Communication setting 21-22 : Reserved 23 : Zero-speed running 2 (having output at stop)	N.A	42	
F5-04	Relay function (T/A3-T/C3)	24 : Cumulative power-on time reached 25 : Frequency-level detection FDT2 output 26 : Frequency 1 reached 27 : Frequency 2 reached 28 : Current 1 reached 29 : Current 2 reached 30 : Timing reached	N.A	0	
F5-05	Relay function (T/A4-T/C4)	31 : AI-1 input limit exceeded 32 : Load becoming 0 33 : Reverse running 34 : Zero current state 35 : Module temperature reached 36 : Software current limit exceeded 37 : Frequency lower limit reached (having output at stop) 38 : Alarm output 39 : Motor overheat warning 40 : Current running time reached 41 : Fault output (There is no output if it is the coast-to-stop fault and under-voltage occurs) 42 : Brake output 43 : MC (Magnetic contactor) output	N.A	0	
F5-07	AO1 function selection	0 : Running frequency 1 : Set frequency 2 : Output current 3 : Output torque (absolute value)	N.A	3	

5.7 Group F6: start and stop control

Function Code	Parameter name	Setting Range	Unit	Default	Commission
F6-00	Start mode	0 : Direct start 1 : Rotational speed tracking restart 2 : Pre-excited start (asynchronous motor)	N.A	0	
F6-03	Startup frequency	0.0 to 10.0	Hz	1.0	
F6-04	Startup frequency active set time	0.0 to 100.0	Sec	0.3	
F6-05	DC injection 1 level	0 to 150	%	0	
F6-06	DC injection 1 active set time	0.0 to 5.0	Sec	0	
F6-07	Acceleration/Deceleration mode	0 : Linear acceleration/ deceleration 3: S-curve acceleration/ deceleration C	N.A	3	
F6-08	Time proportion of S-curve at Accel start	0.0% to Min[(100.0% - F6-09), 80%]	%	80.0	
F6-09	Time proportion of S-curve at Accel end	0.0% to Min[(100.0% - F6-08), 80%]	%	10.0	
F6-10	Stop mode	0 : Decelerate to stop 1 : Coast to stop	N.A	0	
F6-11	DC injection 2 frequency threshold	0.00 Hz to maximum frequency	Hz	0.50	
F6-12	DC Injection 2 delay ON set time	0.0 to 36.0	Sec	0.0	
F6-13	DC injection 2 level	0 to 150	%	30	
F6-14	DC injection 2 active set time	0.0 to 5.0	Sec	0.5	
F6-26	Time proportion of S-curve at Decel start	0.0% to Min[(100.0% - F6-27), 80%]	%	20.0	
F6-27	Time proportion of S-curve at Decel end	0.0% to Min[(100.0% - F6-26), 80%]	%	30.0	

5.8 Group F7: product and software version checking

Function Code	Parameter name	Setting Range	Unit	Default	Commission
F7-08	Product number	N.A.	N.A.	380.00	display
F7-10	Performance software version	N.A.	N.A.	312.xx	display
F7-11	Functional software version	N.A.	N.A.	312.xx	display
F7-15	Performance software temporary version	N.A.	N.A.	0.00	display
F7-16	Functional software temporary version	N.A.	N.A.	0.00	display

5.9 Group F8: auxiliary functions

Function Code	Parameter Name	Setting Range	Unit	Default	Commission
F8-04	Deceleration time 2	0.0 to 6500.0	sec	2.0	
F8-26	Frequency switchover point between deceleration time 1 and deceleration time 2	0.00 to maximum frequency	Hz	0.00	
F8-55	Brake release current threshold	0 to 200	%	5	
F8-56	Brake release frequency threshold	0.00 to 25.00	Hz	0	
F8-57	Brake release delay ON set time	0.0 to 5.0	sec	0.0	
F8-58	Brake apply frequency threshold	0.00 to 25.00	Hz	0.50	
F8-59	Brake apply delay OFF set time	0.0 to 5.0	Sec	0.2	
F8-60	Drive run delay ON set time	0.20 to 10.00	Sec	0.20	
F8-61	MC contactor delay OFF set time	0.00 to 10.00	Sec	0.20	

5.10 Group F9: fault and protection

Function Code	Parameter Name	Setting Range	Unit	Default	Commission
F9-00	Motor thermal protection enable selection	0: disable motor thermal protection; 1: enable motor thermal protection	N.A	1	
F9-01	Motor thermal protection coefficient	0.1 to 10.00	N.A	1.00	
F9-02	Motor thermal protection pre-warning coefficient	50 to 99	%	80	
F9-07	Ground fault detection Enable	0: Disable; 1: Enable detection upon power on; 2: Enable detection upon power on and upon start;	N.A	2	
F9-08	Braking operation voltage level	700 to 800	V	750	
F9-09	Fault auto reset times	0 to 20	N.A	0	
F9-11	Time interval of fault auto reset	0.1 to 100.0	Sec	1.0	
F9-13	Drive output phase loss detection Enable	0: Disable; 1: Enable detection during running; 2: Enable detection upon start and during running	N.A	2	
F9-14	1st fault type	0 to 51	N.A.	N.A.	
F9-15	2nd fault type	0 to 51	N.A.	N.A.	
F9-16	3rd (latest) fault type	0 to 51	N.A.	N.A.	
F9-17	Frequency upon 3rd fault	N.A.	Hz	N.A.	
F9-18	Current upon 3rd fault	N.A.	A	N.A.	
F9-19	Bus voltage upon 3rd fault	N.A.	V	N.A.	
F9-20	Input terminal status upon 3rd fault	N.A.	N.A.	N.A.	

Function Code	Parameter Name	Setting Range	Unit	Default	Commission
F9-21	Output terminal status upon 3rd fault	N.A.	N.A.	N.A.	
F9-22	AC drive status upon 3rd fault	N.A.	N.A.	N.A.	
F9-23	Power-on time upon 3rd fault	N.A.	N.A.	N.A.	

5.11 Group FC: multi-reference

Function Code	Parameter name	Setting Range	Unit	Default	Commission
FC-00	Reference 0	0.0 to 100.0	%	10.0%	
FC-01	Reference 1	0.0 to 100.0	%	100.0%	
FC-02	Reference 2	0.0 to 100.0	%	11.0%	
FC-03	Reference 3	0.0 to 100.0	%	12.0%	
FC-04	Reference 4	0.0 to 100.0	%	40.0%	
FC-05	Reference 5	0.0 to 100.0	%	13.0%	
FC-06	Reference 6	0.0 to 100.0	%	14.0%	
FC-07	Reference 7	0.0 to 100.0	%	15.0%	
FC-08	Reference 8	0.0 to 100.0	%	20.0%	

Attention!

		F4-02 to F4-04 and F4-06 Multi-Reference			
Preset Reference Selector		F4-02	F4-03	F4-04	F4-06
FC-00 : Reference 0	0	OFF	OFF	OFF	OFF
FC-01 : Reference 1	1	ON	OFF	OFF	OFF
FC-02 : Reference 2	2	OFF	ON	OFF	OFF
FC-03 : Reference 3	3	ON	ON	OFF	OFF
FC-04 : Reference 4	4	OFF	OFF	ON	OFF
FC-05 : Reference 5	5	ON	OFF	ON	OFF
FC-06 : Reference 6	6	OFF	ON	ON	OFF
FC-07 : Reference 7	7	ON	ON	ON	OFF
FC-08 : Reference 8	8	OFF	OFF	OFF	ON

5.12 Group FF: drive parameters

Function Code	Parameter name	Setting Range	Unit	Default	Commission
FF-00	Factory password	0 to 65535	N.A.	0	
FF-01	Drive code	1 to 537	N.A.	Model dependent	
FF-02	G/P type selection	1: G type; 2: P type	N.A.	1	
FF-03	Drive rated power	0 to 6553.5	N.A.	Model dependent	display

5.13 Group FP: function code management

Function Code	Parameter name	Setting Range	Unit	Default	Commission
FP-00	User password	0 to 65535	N.A.	0	
FP-01	Parameter initialization	0: No operation 01: Restore factory settings except motor parameters 02: Clear records 04: Restore user backup parameters 501: Back up current user parameters	N.A.	0	
FP-03	Parameter display selection	7-segment			
				0 0	N.A. 00
	Modified parameters: 0: No display 1: Display Customized parameters: 0: No display 1: Display				

5.14 Group A5: control optimization

Function Code	Parameter name	Setting Range	Unit	Default	Commission
A5-06	Under voltage threshold	60.0 to 140.0	%	60.0	100% is 350V
A5-09	Overvoltage tripping level	200.0 to 2500.0	V	810	

5.15 Group U0: monitoring

Function Code	Parameter name	Setting Range	Unit	Default	Commission
U0-00	Running frequency	N.A.	Hz	N.A.	
U0-01	Set frequency	N.A.	Hz	N.A.	
U0-02	Bus voltage	N.A.	V	N.A.	
U0-03	Output voltage	N.A.	V	N.A.	
U0-04	Output current	N.A.	A	N.A.	
U0-05	Output power	N.A.	kW	N.A.	
U0-06	Output torque	N.A.	%	N.A.	
U0-07	DI state	N.A.	N.A.	N.A.	
U0-08	DO state	N.A.	N.A.	N.A.	
U0-09	AI1 voltage	N.A.	V	N.A.	
U0-10	AI2 voltage	N.A.	V	N.A.	
U0-11	AI3 voltage	N.A.	V	N.A.	
U0-41	DI state visual display	N.A.	N.A.	N.A.	
U0-42	DO state visual display	N.A.	N.A.	N.A.	
U0-65	Torque upper limit	N.A.	%	N.A.	

6 Trouble shooting

6.1 Fault codes

Display	Fault Name	Possible Causes	Solutions												
Err02	Overcurrent during acceleration	<ol style="list-style-type: none"> 1. The output circuit is short circuited. 2. The acceleration time is too short. 3. Manual torque boost or V/F curve is not appropriate. 4. The power supply is too low. 5. The startup operation is performed on the rotating motor. 6. A sudden load is added during acceleration. 7. The AC drive model is of too small power class. 	<ol style="list-style-type: none"> 1: Eliminate short circuit. 2: Increase the acceleration time F0-17. 3: Adjust the manual torque boost or V/F curve. 4: Check that the power supply is normal. 5: Select speed tracking restart or start the motor after it stops. 6: Remove the added load. 7: Select a drive of higher power class. 												
Err03	Overcurrent during deceleration	<ol style="list-style-type: none"> 1. The output circuit is short circuited. 2. The deceleration time is too short. 3. The power supply is too low. 4. A sudden load is added during deceleration. 5. The braking resistor is not installed. 	<ol style="list-style-type: none"> 1: Eliminate short circuit. 2: Increase the deceleration time F0-18. 3: Check the power supply, and ensure it is normal. 4: Remove the added load. 5: Install the braking resistor. 												
Err04	Overcurrent at constant speed	<ol style="list-style-type: none"> 1. The output circuit is short circuited. 2. The power supply is too low. 3. A sudden load is added during operation. 4. The AC drive model is of too small power class. 	<ol style="list-style-type: none"> 1: Eliminate short circuit. 2: Adjust power supply to normal range. 3: Remove the added load. 4: Select a drive of higher power class. 												
Err05	Overvoltage during acceleration	<ol style="list-style-type: none"> 1. The DC bus voltage is too high[☆]. 2. An external force drives the motor during acceleration. 3. The acceleration time is too short. 4. The braking resistor is not installed. 	<ol style="list-style-type: none"> 1: Replace with a proper braking resistor. 2: Cancel the external force or install braking resistor. 3: Increase the acceleration time. 4: Install a braking resistor. 												
Err06	Overvoltage during deceleration	<ol style="list-style-type: none"> 1. The DC bus voltage is too high[☆]. 2. An external force drives the motor during deceleration. 3. The deceleration time is too short. 4. The braking resistor is not installed. 	<ol style="list-style-type: none"> 1: Replace with a proper braking resistor. 2: Cancel the external force or install braking resistor. 3: Increase the deceleration time. 4: Install the braking resistor. 												
Err07	Overvoltage at constant speed	<ol style="list-style-type: none"> 1. The DC bus voltage is too high[☆]. 2. An external force drives the motor during deceleration. 	<ol style="list-style-type: none"> 1: Replace with a proper braking resistor. 2: Cancel the external force. 												
[☆] : Voltage thresholds <table border="1" style="width: 100%; border-collapse: collapse;"> <thead> <tr> <th>Voltage Class</th> <th>DC Bus Overvoltage threshold</th> <th>DC Bus Undervoltage threshold</th> <th>Braking operation level</th> </tr> </thead> <tbody> <tr> <td>Three-phase 220V</td> <td>400VDC</td> <td>200VDC</td> <td>380VDC</td> </tr> <tr> <td>Three-phase 380V</td> <td>810VDC</td> <td>350VDC</td> <td>750VDC</td> </tr> </tbody> </table>				Voltage Class	DC Bus Overvoltage threshold	DC Bus Undervoltage threshold	Braking operation level	Three-phase 220V	400VDC	200VDC	380VDC	Three-phase 380V	810VDC	350VDC	750VDC
Voltage Class	DC Bus Overvoltage threshold	DC Bus Undervoltage threshold	Braking operation level												
Three-phase 220V	400VDC	200VDC	380VDC												
Three-phase 380V	810VDC	350VDC	750VDC												
Err08	Control power fault	The input voltage exceeds the allowed range.	Adjust the input voltage to within the allowed range.												

Display	Fault Name	Possible Causes	Solutions
Err09	Undervoltage	<ol style="list-style-type: none"> 1. Instantaneous power failure occurs. 2. The input voltage exceeds the allowed range 3. The DC bus voltage is too low[*]. 4. The rectifier bridge and buffer resistor are faulty. 5. The drive board is faulty. 6. The control board is faulty. 	<ol style="list-style-type: none"> 1: Reset the fault. 2: Adjust the input voltage to within the allowed range. 3 to 6: Seek for maintenance.
Err10	Drive overload	<ol style="list-style-type: none"> 1. The load is too heavy or the rotor is locked. 2. The drive is of too small power class. 	<ol style="list-style-type: none"> 1: Reduce the load, or check the motor, or check the machine whether it is locking the rotor. 2: Select a drive of higher power class.
Err11	Motor overload	<ol style="list-style-type: none"> 1. F9-01 is too small. 2. The load is too heavy or the rotor is locked. 3. The drive is of too small power class. 	<ol style="list-style-type: none"> 1: Set F9-01 correctly. 2: Reduce load, or check motor, or check the machine whether it is locking the rotor. 3: Select a drive of larger power class.
Err12	Power input phase loss	<ol style="list-style-type: none"> 1. The three-phase power supply is abnormal. 2. The drive board is faulty. 3. The lightening protection board is faulty. 4. The control board is faulty. 	<ol style="list-style-type: none"> 1: Check the power supply. 2 to 4: Seek for maintenance.
Err13	One drive output phase loss	<ol style="list-style-type: none"> 1. The cable between drive and motor is faulty. 2. The drive's three-phase output is unbalanced when the motor is running. 3. The drive board is faulty 4. The IGBT is faulty. 	<ol style="list-style-type: none"> 1: Check the cable. 2: Check the motor windings. 3 to 4: Seek for maintenance.
Err14	IGBT overheat	<ol style="list-style-type: none"> 1. The ambient temperature is too high. 2. The air filter is blocked. 3. The cooling fan is damaged. 4. The thermal sensor of IGBT is damaged. 5. The IGBT is damaged. 	<ol style="list-style-type: none"> 1: Reduce the ambient temperature. 2: Clean the air filter. 3 to 5: Seek for maintenance.
Err15	External equipment fault	<ol style="list-style-type: none"> 1. External fault signal is input via DI. 2. External fault signal is input via VDI. 	Reset the fault.
Err16	Communication fault	<ol style="list-style-type: none"> 1. The host computer is abnormal. 2. The communication cable is faulty. 3. The extension card type set in F0-28 is incorrect. 4. The communication parameters in group FD are set improperly. 	<ol style="list-style-type: none"> 1: Check cabling of the host computer. 2: Check the communication cabling. 3: Set F0-28 correctly. 4: Set the communication parameters properly.
Err18	Current detection fault	The drive board is faulty.	Replace the drive board.
Err19	Motor tuning fault	<ol style="list-style-type: none"> 1. Motor parameters are wrong. 2. Motor tuning overtime. 	<ol style="list-style-type: none"> 1. Check motor parameters F1-00 to F1-05. 2. Check the wiring between drive and motor.
Err21	EEPROM read-write fault	The EEPROM chip is damaged.	Replace the main control board.
Err23	Short circuit to ground	The motor is short-circuited to ground.	Replace the cables or motor.
Err26	Accumulative running time reached	The accumulative running time reaches the setting of F8-17.	Clear the record by performing parameter initialization (set FP-01 to 2).
Err27	User-defined fault 1	<ol style="list-style-type: none"> 1. The user-defined fault 1 signal is input via DI. 2. User-defined fault 1 signal is input via VDI. 	Reset the fault.

Display	Fault Name	Possible Causes	Solutions
Err28	User-defined fault 2	<ol style="list-style-type: none"> 1. The user-defined fault 2 signal is input via DI 2. The user-defined fault 2 signal is input via VDI. 	Reset the fault.
Err29	Accumulative power-on time reached	The accumulative power-on time reaches the setting of F8-16.	Clear the record by performing parameter initialization (set FP-01 to 2).
Err30	Off load fault	Offload when it's running.	Check the connection between motor and load.
Err31	PID feedback lost during running	The PID feedback is lower than FA-26.	Check the PID feedback signal or set FA-26 to a proper value.
Err40	Quick current limit	<ol style="list-style-type: none"> 1. The load is too heavy or the rotor is locked. 2. The drive is of too small power class. 	<ol style="list-style-type: none"> 1: Reduce the load, or check the motor, or check the machine whether it is locking the rotor. 2: Select a drive of higher power class.
Err41	Motor switchover fault during running	The current motor is switched over via a terminal during running of the AC drive.	Switch over the motor only after the AC drive stops.
Err61	Two or three drive output phases loss	<ol style="list-style-type: none"> 1. The drive output connections get loose; 2. The output contactor gets wrongly operated or malfunctions. 	<ol style="list-style-type: none"> 1. Check drive output connections; 2. Check drive output contactor.

6.2 Common symptoms and diagnostics

Fault Name	Possible Causes	Solutions
There is no display at power-on.	<ol style="list-style-type: none"> 1. There is no power supply or the power supply is too low. 2. The switching power supply on the drive board is faulty. 3. The rectifier bridge is damaged. 4. The buffer resistor of the drive is damaged. 5. The control board or the keypad is faulty. 6. The cable between the control board and the drive board or keypad breaks. 	<ol style="list-style-type: none"> 1: Check the power supply. 2 to 5: Seek for maintenance. 6: Re-connect the 4-core and 28-core flat cables, or seek for maintenance.
"HC" is displayed at power-on.	<ol style="list-style-type: none"> 1. The cable between the drive board and the control board is in poor contact. 2. The control board is damaged. 3. The motor winding or the motor cable is short-circuited to the ground. 4. The power supply is too low. 	<ol style="list-style-type: none"> 1: Re-connect the 4-core and 28-core flat cables, or seek for maintenance. 2: Seek for maintenance. 3: Check the motor or replace it, and check the motor cable. 4. Check the power supply according to chapter 1.3.
The display is normal upon power-on, but "HC" is displayed after start and the motor stops immediately.	<ol style="list-style-type: none"> 1. The cooling fan is damaged or the rotor is locked. 2. A certain terminal is short-circuited. 	<ol style="list-style-type: none"> 1: Replace cooling fan, or check the machine whether it is locking the rotor. 2: Eliminate short circuit.
Err14 is reported frequently.	<ol style="list-style-type: none"> 1. The carrier frequency is set too high. 2. The cooling fan is damaged, or the air filter is blocked. 3. Components (thermal coupler or others) inside the drive are damaged. 	<ol style="list-style-type: none"> 1: Reduce F0-15. 2: Replace the fan and clean the air filter. 3: Seek for maintenance.
The motor does not rotate after the AC drive outputs a non-zero reference.	<ol style="list-style-type: none"> 1. The motor or motor cable is damaged. 2. The motor parameters are set improperly. 3. The cable between the drive board and the control board is in poor contact. 4. The drive board is faulty. 5. The rotor is locked. 	<ol style="list-style-type: none"> 1: Check the motor, or check the cable between the drive and the motor. 2: Check and re-set motor parameters. 3: Re-connect the 4-core and 28-core flat cables, or seek for maintenance. 4: Seek for maintenance. 5: Check the machine whether it is locking the rotor.
The DI terminals are disabled.	<ol style="list-style-type: none"> 1. The DI parameters are set incorrectly. 2. The input signal is incorrect. 3. The wire jumper between OP and +24V is in poor contact. 4. The control board is faulty. 	<ol style="list-style-type: none"> 1: Check and reset DI parameters in group F4. 2: Check the input signals, or check the input cable. 3: Check the jumper between OP and +24 V. 4: Seek for maintenance.
The drive reports overcurrent and overvoltage frequently.	<ol style="list-style-type: none"> 1. The motor parameters are set improperly. 2. The acceleration/deceleration time is too small. 3. The load fluctuates. 	<ol style="list-style-type: none"> 1: Reset motor parameters. 2: Set proper acceleration/deceleration time. 3: Check the machine, or seek for maintenance.

Revision History

Date	Version	Change Description
July 2015	V0.5	First issue.
Dec 2016	A01	Modified product name, designation rule and nameplate.
Nov 2018	A02	Updated logo.