

## **preface**

First of all, thank you for purchasing the FST-503 series inverter developed and produced by our company!

FST-503 series frequency converter is a general multi-function frequency converter, V / F control of AC synchronous motor, can be used to drive textile, paper, wire drawing, machine tool, packaging, food, fan, water pump and various automatic production equipment. FST-503 series frequency converter has large starting torque, simple debugging, and can realize 7-section speed operation, system closed-loop process control and networking functions.

This manual introduces the configuration function and use method of FST-503 series inverter.

Please use the product after understanding the safety precautions. Read this instruction manual carefully before first using the FST-503 series frequency converter (installation, operation, maintenance, inspection, etc.). The equipment supporting manufacturer should send this manual to the end user along with the equipment for subsequent reference.

### **matters need attention**

- ◆ To illustrate the detailed part of the product, the legend in this manual sometimes removes the status of the cover or safety cover. When using this product, please be sure to install the shell or cover according to the regulations, and operate according to the instructions.
- ◆ The legend in this instruction for use may differ from the product you order.
- ◆ Due to product changes in upgrade or specification and to improve the convenience and accuracy of the specification.

## brief introduction

**The basic configuration and functions of the FST-503 series are as follows:**

Enter the output terminal	3 S (multifunction digital input terminal) 1 VR (given by the external potentiometer) 2 Y (Open circuit collector output)
control method	V/F
To simulate a given way	Straight line mode
Multi-section speed	The 7-segment speeds can be achieved
simple and easy PLC	Can achieve 7 periods of regular operation
Communication function	Bring your own 485 communication port
PID control	Yes (with constant pressure water supply mode)
V/F way	have

**Out of the box inspection:**

When unpacking, please carefully confirm:

1) Whether the model and inverter rating of the machine nameplate are consistent with your order. The box contains the machine, product certificate and user operation manual you ordered.

2) Whether the product is damaged during transportation; if any omission or damage occurs, please contact the company or your supplier quickly.

Initial use:

For the users who use the product for the first time, they should first read the manual carefully. If you have doubts about some functions and performance, please consult our technical support staff for help for the correct use of this product.

Due to the continuous improvement of the product, the information provided by the Company is subject to change without notice.

## catalogue

<b>preface</b> .....	<b>- 1 -</b>
<b>brief introduction</b> .....	<b>- 2 -</b>
<b>Chapter I Safety Information and Precautions</b> .....	<b>- 4 -</b>
1.1 Safety matters .....	- 4 -
1.2 Precautions .....	- 6 -
<b>Chapter II: Product Information</b> .....	<b>- 9 -</b>
2.1 naming rules .....	- 9 -
2.2 Model and technical data of frequency converter .....	- 9 -
2.3 Technical Specifications .....	- 10 -
2.4 Daily maintenance and maintenance of the frequency converter .....	- 11 -
2.5 Warranty description for the frequency converter .....	- 13 -
<b>Chapter III: Mechanical and Electrical Installation</b> .....	<b>- 14 -</b>
3.1 Electrical installation .....	- 14 -
3.2 Wiring terminals .....	- 15 -
3.3 Application and precautions of peripheral equipment .....	- 16 -
<b>Chapter IV Operation</b> .....	<b>- 17 -</b>
4.1 Introduction of the operation and display interface .....	- 17 -
4.2 Functional parameter table .....	- 18 -
<b>Chapter V Fault diagnosis and Countermeasures</b> .....	<b>- 35 -</b>
5.1 Fault alarm and countermeasures .....	- 35 -
5.2 Common faults and their handling methods .....	- 38 -
<b>Chapter VI Communication Agreement</b> .....	<b>- 40 -</b>
6.1 Agreement Content .....	- 40 -
6.2 Application mode .....	- 40 -
6.3 Bus structure .....	- 40 -
6.4 Agreement description .....	- 40 -
6.5 Communication data structure .....	- 41 -
6.6 Description of the communication parameters of the FA group .....	- 46 -

## Chapter I Safety Information and Precautions

Security definition:

In this manual, safety precautions are given in the following two categories:



**Danger:** a danger caused by not operating as required that may lead to serious injury or even death;











**Note:** The danger caused by no required operation may lead to moderate injury or minor injury, and equipment damage;

Please read this chapter carefully when installing, debugging and repairing the system, and be sure to follow the safety precautions required in this chapter. Any injury and loss caused by the violation has nothing to do with the Company.

### 1.1 Security matters

Use the stage	security classification	item
Before installation	 danger	<ul style="list-style-type: none"> <li>◆ If the control system is flooded, missing or damaged, please do not install!</li> <li>◆ When the packing list does not match with the physical name, please do not install it!</li> </ul>
	 pay attention to	<ul style="list-style-type: none"> <li>◆ Handling should be lifted gently gently, otherwise there is a danger of damage to the equipment!</li> <li>◆ Do not use damaged drivers or missing frequency converter. In danger of injury!</li> <li>◆ Do not touch the components of the control system by hand, otherwise there is a danger of electrostatic damage!</li> </ul>
When installing	 danger	<ul style="list-style-type: none"> <li>◆ Please install on flame retardant objects such as metal; stay away from combustible objects. Otherwise, it may cause a fire alarm!</li> <li>◆ Do not unscrew the fixed bolts of the equipment components, especially the bolts with red marks!</li> </ul>
	 pay attention to	<ul style="list-style-type: none"> <li>◆ Do not allow the lead head or screw to drop into the drive. Otherwise cause drive damage!</li> <li>◆ Install the drive where you can vibrate less to avoid direct sunlight.</li> <li>◆ When two or more frequency converters are placed in the same cabinet, please pay attention to the installation position to ensure the heat dissipation effect.</li> </ul>
When wiring	 danger	<ul style="list-style-type: none"> <li>◆ Must be constructed by professional electrical engineering personnel, otherwise there will be unexpected danger!</li> <li>◆ There must be a circuit breaker separated between the frequency converter and the power supply, otherwise a fire may occur!</li> <li>◆ Ensure that the power supply is at zero energy before wiring, otherwise</li> </ul>

Use the stage	security classification	item
		<p>there is a risk of electric shock!</p> <ul style="list-style-type: none"> <li>◆ Please ground the frequency converter correctly according to the standard, otherwise there is a danger of electric shock!</li> </ul>
	 pay attention to	<ul style="list-style-type: none"> <li>◆ Never connect the input power to the output terminal (U, V, W). Pay attention to the terminal mark, do not connect the wrong line! Otherwise cause drive damage!</li> <li>◆ Refer to the recommendations in the wire diameter used. Otherwise, an accident may occur!</li> </ul>
Before the electricity	 danger	<ul style="list-style-type: none"> <li>◆ Please confirm that the voltage level of the input power supply is consistent with the rated voltage level of the frequency converter; the wiring position of the power input terminal (L1, L2) and output terminal (U, V, W) is correct; and check whether the peripheral circuit and the connected circuit is fastened, otherwise the drive is damaged!</li> <li>◆ Any part of the frequency converter does not need to withstand pressure test, the product has been tested when the factory. Otherwise, it may cause an accident!</li> </ul>
	 pay attention to	<ul style="list-style-type: none"> <li>◆ The frequency converter must cover the cover plate before the power. Otherwise, it may cause an electric shock!</li> <li>◆ The wiring of all peripheral accessories must follow the instructions of this manual and follow the circuit connection method provided in this manual. Otherwise, it will cause an accident!</li> </ul>
After the electricity	 danger	<ul style="list-style-type: none"> <li>◆ Do not open the cover after power. Otherwise, there is a risk of electric shock!</li> <li>◆ Do not touch any input / output terminals of the frequency converter. Otherwise, there is a danger of electric shock!</li> </ul>
	 pay attention to	<ul style="list-style-type: none"> <li>◆ If parameter tuning is required, please pay attention to the danger of injury in the motor rotation. Otherwise, it may cause an accident!</li> <li>◆ Do not arbitrarily change the parameters of the frequency converter manufacturer at will. Otherwise, it may cause the damage to the equipment!</li> </ul>
in service	 danger	<ul style="list-style-type: none"> <li>◆ Non-professional technical personnel do not detect signals in operation. Otherwise, it may cause personal injury or equipment damage!</li> <li>◆ Do not touch the cooling fan and the discharge resistance to test the temperature. Otherwise, it may cause burns!</li> </ul>
	 pay attention to	<ul style="list-style-type: none"> <li>◆ During the operation of the frequency converter, something should be avoided from falling into the equipment. Otherwise, cause equipment damage!</li> <li>◆ Do not use the contactor on-off method to control the start and stop of the drive. Otherwise, cause equipment damage!</li> </ul>

Use the stage	security classification	item
Maintenance	 danger	<ul style="list-style-type: none"> <li>◆ Personnel without professional training should not repair and maintain the frequency converter. Otherwise, cause personal injury or equipment damage!</li> <li>◆ Do not repair and maintain the equipment with electricity. Otherwise, there is a danger of electric shock!</li> <li>◆ Check that the input power of the inverter can be cut off for 10 minutes. Otherwise, the residual charge on the capacitor will cause harm to people!</li> <li>◆ Before maintenance on the converter, ensure the converter is safely disconnected from all power sources.</li> <li>◆ All pluggable inserts must be plugged in case of power failure!</li> <li>◆ Setting and the parameters must be checked after replacing the frequency converter.</li> </ul>
	 pay attention to	<ul style="list-style-type: none"> <li>◆ The rotating power supply feeds power to the converter so that the converter will be on even when the motor stops and the power is cut off. Ensure sure the motor is safely disconnected from the inverter.</li> </ul>

### 1.2 Precautions

#### 1) Electric leakage protector RCD requirements

When the equipment is in operation, a large leakage current will flow through the protective grounding conductor. Please install the B-type leakage protector (RCD) on the primary side of the power supply. When selecting the leakage protector (RCD), consider the possible transient and steady state ground drain current when the equipment is up and running, select the special RCD with inhibitory high harmonic measures, or the general RCD with large residual current.

#### 2) Motor insulation inspection

Before the first use and regular inspection, the motor insulation inspection should be done to prevent damage to the frequency converter due to the insulation failure of the motor winding. During the insulation inspection, the motor connection must be separated from the frequency converter. It is recommended to use the 500V voltage type megohmmeter, and ensure that the measured insulation resistance is not less than 5M Ω .

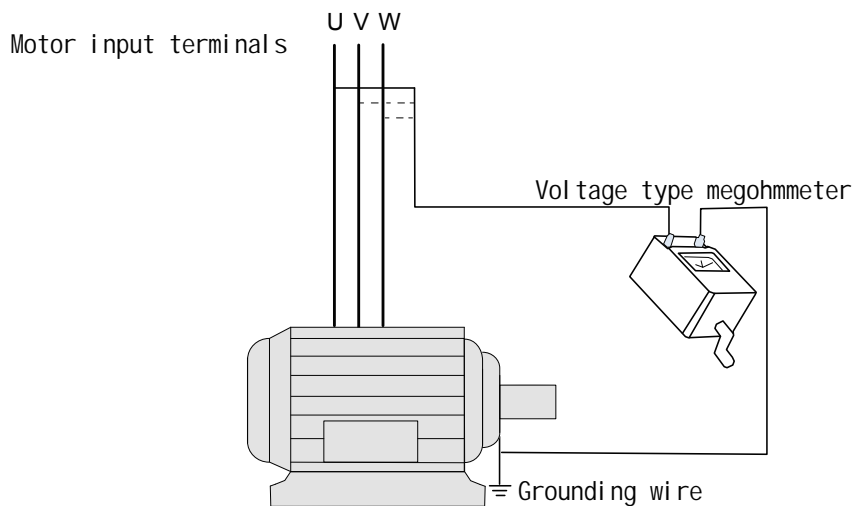

### 3) Thermal protection of the motor

If the motor does not match the rated capacity of the converter, especially when the rated power of the converter is greater than the rated power of the motor, be sure to adjust the motor protection parameters in the converter or install a thermal relay in front of the motor to protect the motor.

### 4) Operation above the power frequency

This inverter provides an output frequency of 0 Hz to 630 Hz. If the customer needs to operate above 50Hz, please consider the endurance of the mechanical device.

### 5) The vibration of the mechanical device

At some output frequencies, the frequency converter may encounter the mechanical resonance point of the load device, which can be avoided by setting the jump frequency parameters in the frequency converter.

### 6) About the motor heating and noise

Because the output voltage of the frequency converter is PWM wave, which contains certain harmonics, the temperature rise, noise and vibration of the motor will be slightly increased compared with the power frequency operation.

### 7) Capacity of voltage sensitive device or improved power factor on the output side

The output of the converter is PWM wave. If the output side is installed with capacitor or transistor for lightning protection, it is easy to cause instantaneous overcurrent of the converter or even damage the frequency converter. Please do not use it.

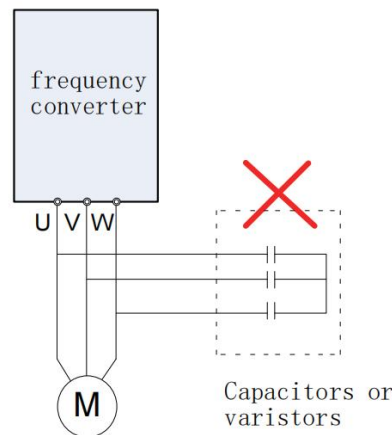

### 8) Use beyond the rated voltage value

It is not suitable to use the frequency converter outside the allowable operating voltage range specified in the instruction manual, which is easy to cause damage to the devices in the frequency converter. If necessary, use the corresponding boost or step-down device to change the power supply and input it to the frequency converter.

### 9) Lightning and lightning impact protection

Although this series of frequency converter is equipped with lightning overcurrent protection device, which has a certain self-protection ability for the induction of lightning, but for lightning frequency, customers should also install lightning protection device at the front end of the frequency converter.

10) Altitude and falling forehead use

In the altitude of more than 1000m, the heat dissipation effect of the frequency converter becomes poor due to the thin air, so it is necessary to reduce the use. Please consult our company for technical consultation on this situation.

11) Some special usage

If customers need to use the methods other than the suggested wiring diagram provided in this manual, such as the common DC bus, please consult our company.

12) Pay attention to the frequency converter

An explosion may occur in the electrolytic capacitor of the main circuit and on the printed board. Plastic parts will produce toxic gas when burned. Please treat it as industrial waste.

13) About the adaptation of the motor

- The standard adaptation motor is a quadrupole cage induction induction motor. If the motor is not mentioned above, please select the frequency converter according to the rated current of the motor.
- The cooling fan of the non-frequency conversion motor is coaxial connected with the rotor shaft, and the cooling effect of the fan is reduced when the speed is reduced. Therefore, a strong exhaust fan should be added to the frequency conversion motor or replaced when the motor is overheated.
- The frequency converter has been built in to adapt the standard parameters of the motor. It is necessary to adjust or modify the default value according to the actual situation to meet the actual value as far as possible, otherwise the operation effect and protection performance will be affected.
- A short circuit inside the cable or motor will cause the frequency converter alarm, or even blast the machine. Therefore, please first conduct an insulation short-circuit test on the initially installed motor and cable, which should be conducted frequently in daily maintenance. Note that the inverter must be completely disconnected from the test part.



## Chapter II on-product information

### 2.1 naming rules

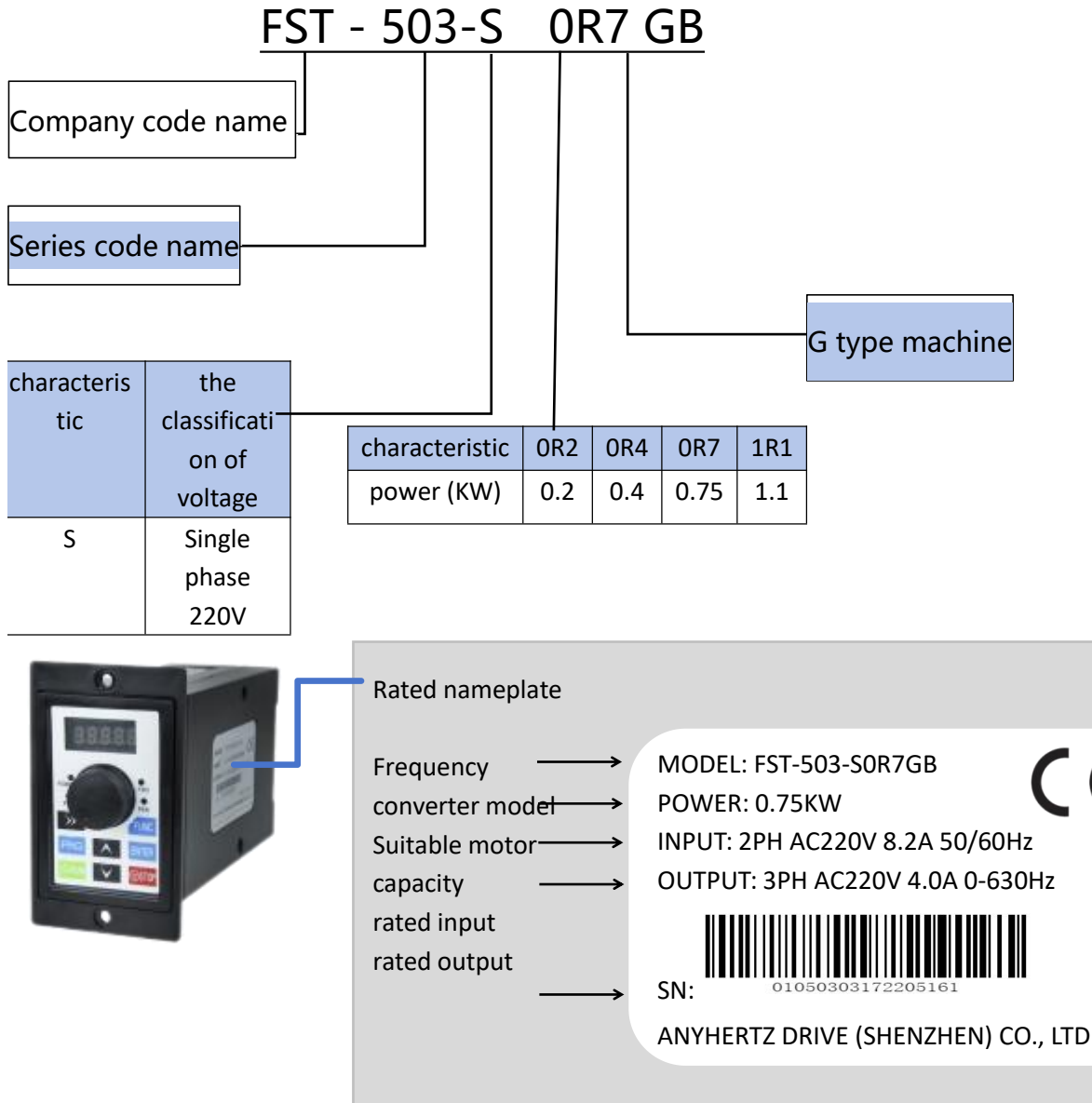

Figure 2-1 Naming rules and nameplate information

### 2.2 Model and technical data of frequency converter

Frequency converter model	input voltage	Power Supply Capacity (KVA)	input current on (A)	output (A)	Adapter to the motor power (kw)
FST-503-SOR2GB	Single-phase of 220V scope: -15%~20%	0.5	3.2	1.6	0.2
FST-503-SOR 4GB		1.0	5.4	2.3	0.4
FST-503-SOR7GB		1.5	8.2	3.7	0.75
FST-503-S 1R1GB		3.0	14.0	5.5	1.1

## 2.3 Technical Specifications

Table 2-2 Technical Specification for FST-503 frequency converter

project		specifications
basic function	maximal frequency	630Hz
	carrier frequency	1 kHz ~ 16 kHz; carrier frequency can be adjusted according to load characteristics
	Input the frequency resolution	Number setting: 0.01Hz Simulation setting: maximum frequency 0.025%
	control method	V/F control
	pull-in torque	Type-G machine: 150%
	Speed range	1: 50
	Steady speed accuracy	± 1%
	overload capacity	The G-type machine has 150% rated current for 60s
	Recurrent ascension	Automatic torque lift; manual torque lift 0.1%~30.0%
	V/F curve	Line V / F, multipoint V / F, and square V / F
	Add deceleration curve	Linear acceleration and deceleration mode, S-curve acceleration and deceleration mode; Two sets of acceleration and deceleration time; The acceleration and deceleration time range is from 0.00 seconds to 300.00 minutes
	electronic control	Point movement frequency range: 0.00Hz ~ maximum frequency; point acceleration and deceleration time 0.00s ~300.00s
	Simple PLC, multi-segment speed operation	Up to 7 segments are run by the built-in PLC or control terminal
	built-in PID	It can easily realize the closed-loop process control system
	Automatic Voltage Adjustment (AVR)	When the power grid voltage changes, it can automatically keep the output voltage constant
	Overloss speed control	Automatic limit current during operation to prevent frequent overcurrent trip
Quick flow restriction function	Minimize the overcurrent fault, and protect the normal operation of the frequency converter	
Speed tracking and re-start function	Can start the motor rotating at high speed	
Continuous operation function of instantaneous power outage	Even if the power grid has a short time of power outage, it can also ensure fault-free continuous operation	
Personalized function	Power-on the safety self-inspection of the peripheral equipment	It can realize the safety detection of the peripheral equipment, such as grounding and short circuit
	FUNC key	Programmable keys: command channel switch / positive and reverse run / click run function selection

project		specifications
	Long control	Given the length control function
move	Run the command channel	Three kinds of channels: operation panel given, control terminal given, serial communication port given. It can be switched in various ways
	frequency source	Digital given, analog voltage given, multispeed, PLC, PID, serial port given.
	input terminal	Three digital input terminals, one of which can be a high-speed pulse input An analog input terminal, where VR can only be used as a voltage input
	leading-out terminal	Two digital output terminals
other	defensive function	Short-circuit detection, input and output phase deficiency protection, overcurrent protection, overvoltage protection, undervoltage protection, overheating protection, overload protection, etc
	Choose accessories	Optional external keyboard (external keyboard with potentiometer), brake components, external lead keyboard line, etc
environment	Where to use	Indoor, not directly exposed to the sun, no dust, corrosive gas, combustible gas, oil mist, water steam, dripping water or salt, etc
	above sea level	1000m, higher than 1000m
	ambient temperature	-10℃ ~ + 40℃ (ambient temperature is 40℃ ~ 50℃, please decrease for use)
	humidity	Less than 95% RH, and the anhydrous beads were condensed
	vibrate	Less than 5.9m/s <sup>2</sup> (0.6g)
	Storage temperature	- 20℃ ~ + 60℃

## 2.4 Daily maintenance and maintenance of the frequency converter

### 2.4.1 Daily maintenance

Due to the influence of environmental temperature, humidity, dust and vibration, the devices inside the converter will be aging, leading to the potential failure of the converter or reducing the service life of the converter. Therefore, it is necessary to carry out the daily and regular maintenance and maintenance of the frequency converter.



pay attention to

- ◆ Note that there is still a high voltage on the filter capacitance after the power supply is disconnected, so the inverter should not repair or maintain the frequency converter immediately. Must wait until the charge light is off after the multimeter test bus voltage is not more than 36V.

Daily inspection items:

- 1) Whether the sound changes are abnormal during the motor operation;
- 2) Whether the vibration is generated during the motor operation;
- 3) Whether the installation environment of the frequency converter changes;

- 4) Whether the frequency converter cooling fan works normally;
- 5) Whether the inverter is overheated.

Daily cleaning:

- 1) Always keep the frequency converter clean;
- 2) Effectively remove the dust on the surface area of the converter to prevent the dust from entering the converter. Especially the metal dust;
- 3) Effectively remove the oil pollution from the inverter cooling fan.

**2.4.2 Periodic inspection**

- 1) Check the air duct, and clean it regularly;
- 2) Check whether the screws are loose;
- 3) Check the frequency converter;
- 4) Check whether the wiring terminals have arc pulling marks;
- 5) Insulation test of the main circuit.
  - Note: When measuring the insulation resistance with the megohm meter (please DC 500V megohm meter), remove the main return route from the frequency converter. Do not test the control loop insulation with an insulation resistance meter. No high pressure testing (completed on delivery).

**2.4.3 Replace the vulnerable parts of the frequency converter**

The vulnerable parts of frequency converter mainly include cooling fan and electrolytic capacitor for filter, whose life is closely related to the service environment and maintenance status. General life time is:

Device name	Life time
electric fan	2 ~ 3 Years
electrolytic capacitor	4 ~ 5 Years

The user can determine the replacement period according to the running time.

- cooling fan
  - Possible causes of damage: bearing wear, blade aging.
  - Identification standard: whether there are cracks in fan blades, and whether there is abnormal vibration sound when startup.
- Filter the electrolytic capacitance
  - Possible damage causes: poor quality of the input power supply, high ambient temperature, frequent load hopping, and electrolyte aging.
  - Discrimination standard: whether there is liquid leakage, whether the safety valve has been protruding, the determination of electrostatic capacitor, the measurement of insulation resistance.

**2.4.4 Storage of the frequency converter**

After purchasing the frequency converter, the temporary storage and long-term storage must pay attention to the following points:

- When storing, try to put it into the packing box of the company according to the original packaging.
- Long time storage will lead to the deterioration of the electrolytic capacitor. It must ensure that the primary power is on within 2 years, the power on time is at least 5 hours, and the input voltage must be slowly raised to the rated value with the voltage regulator.

## **2.5 Warranty description for the frequency converter**

Free warranty only refers to the frequency converter itself.

1) In normal use, failure or damage, our company is responsible for 12 months warranty (from the manufacturing date, to

Barcode on the fuselage shall prevail), more than 12 months, will be charged reasonable maintenance fees;

2) Within 12 months, a certain maintenance fee shall be charged in the following cases:

- Machine damage caused by the user not to follow the provisions in the user manual;
- Damage caused by fire, flood, and abnormal voltage;
- Damage caused when the frequency converter is used for abnormal function.

The relevant service fee shall be calculated according to the unified standard of the manufacturer. If there is a contract, it shall be dealt with on the principle of contract priority.

## Chapter III Mechanical and electrical installation

### 3.1 Electrical installation

#### 3.1.1 Selection guidance of peripheral electrical components

Table 3-1 Guidance on selection of peripheral electrical components of FST-503

Frequency converter model	air switch (MCCB) A	Recommended contactor A	Input side main loop wire (mm)	Output side main loop wire (mm)	Control loop conductor (mm)
FST-503-S0R2GB	6	9	0.75	0.75	0.5
FST-503-S0R4GB	6	9	0.75	0.75	0.5
FST-503-S0R7GB	10	12	0.75	0.75	0.5
FST-503-S1R1GB	16	18	1.5	1.5	0.5

#### 3.1.2 Description of the wiring terminal

1) Description of the main loop terminal:

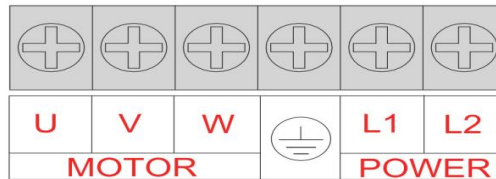

Fig. 3-1 Distribution of the main loop terminals of the single-phase frequency converter

Terminal mark	name	explain
L1、L2	Single-phase power supply input terminal	Single-phase 220V AC power supply connection point
U、V、W	Inverter output terminal	Connect to the three-phase motor
	earth terminal	earth terminal

2) Description of the control loop terminal:

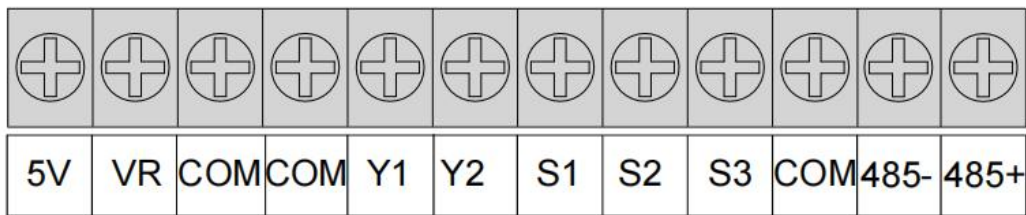

Table 3-3 Wiring mode of the main loop of the frequency converter

class	Terminal symbol	Terminal name	function declaration
source	5V-COM	External 5V power supply	Provide + 5V power supply, generally used as external potentiometer working supply, digital output terminal and external sensor power supply
analog input	VR-COM	Analog quantity input terminal	1. Input voltage range: DC 0V~10V (it can be customized for non-standard to-10VDC~ + 10VDC) 2. Input impedance: 100 kΩ

digital input	S1-COM	Digital input 1	1, light lotus root isolation. 2. Input impedance: 3.3 kΩ
	S2-COM	Digital input 2	
	S3-COM	Digital input 3	
numeric output	Y1-COM	numeric output	Light lotus root isolation, open circuit collector output, load current 0 ~ 500 mA
	Y2-COM		
Auxiliary interface	485+/485-	485 Communication interface	Standard 485 interface

3.2 Wiring terminals

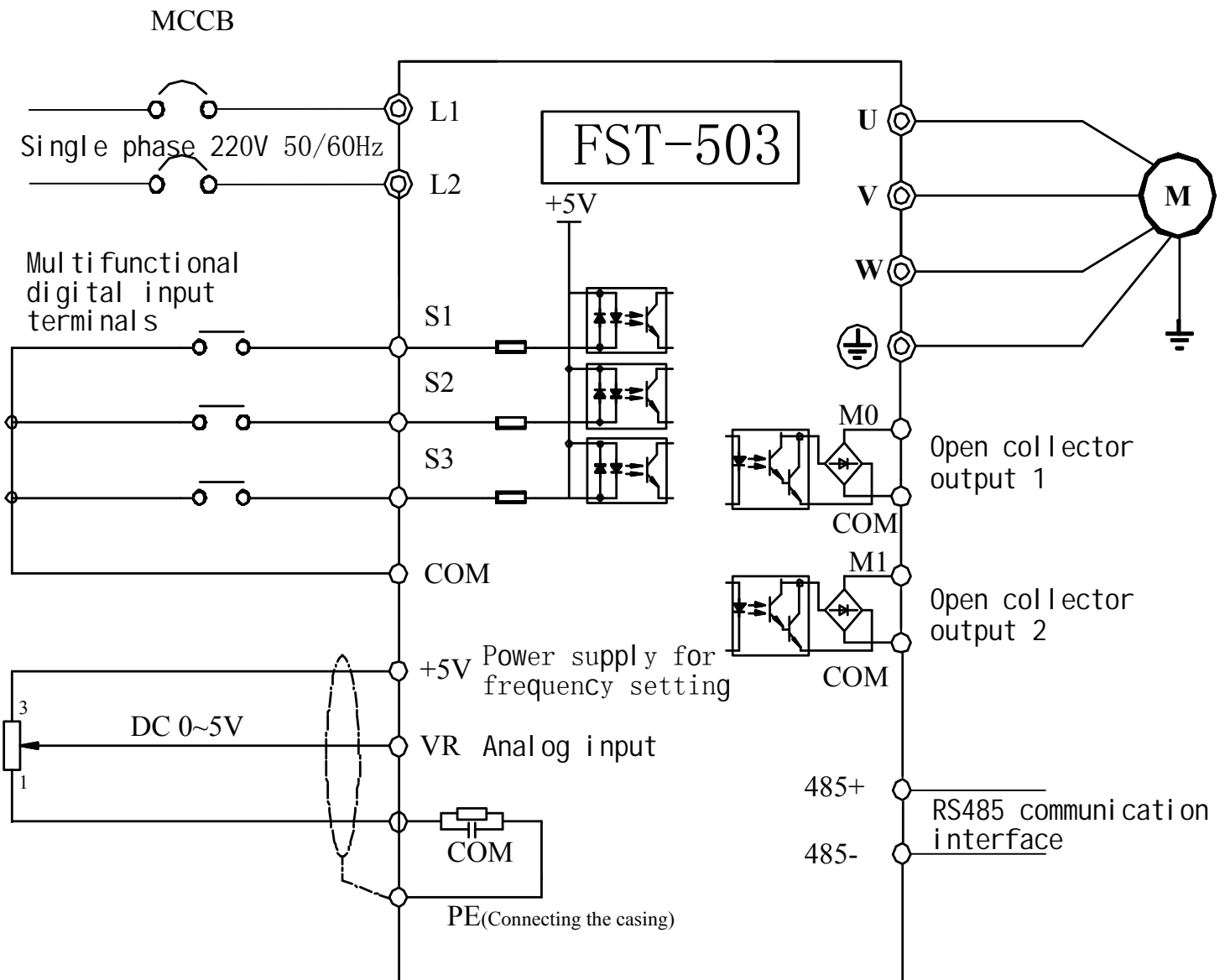

Figure 3-3 applies to the 503 series

### 3.3 Application and precautions of peripheral equipment

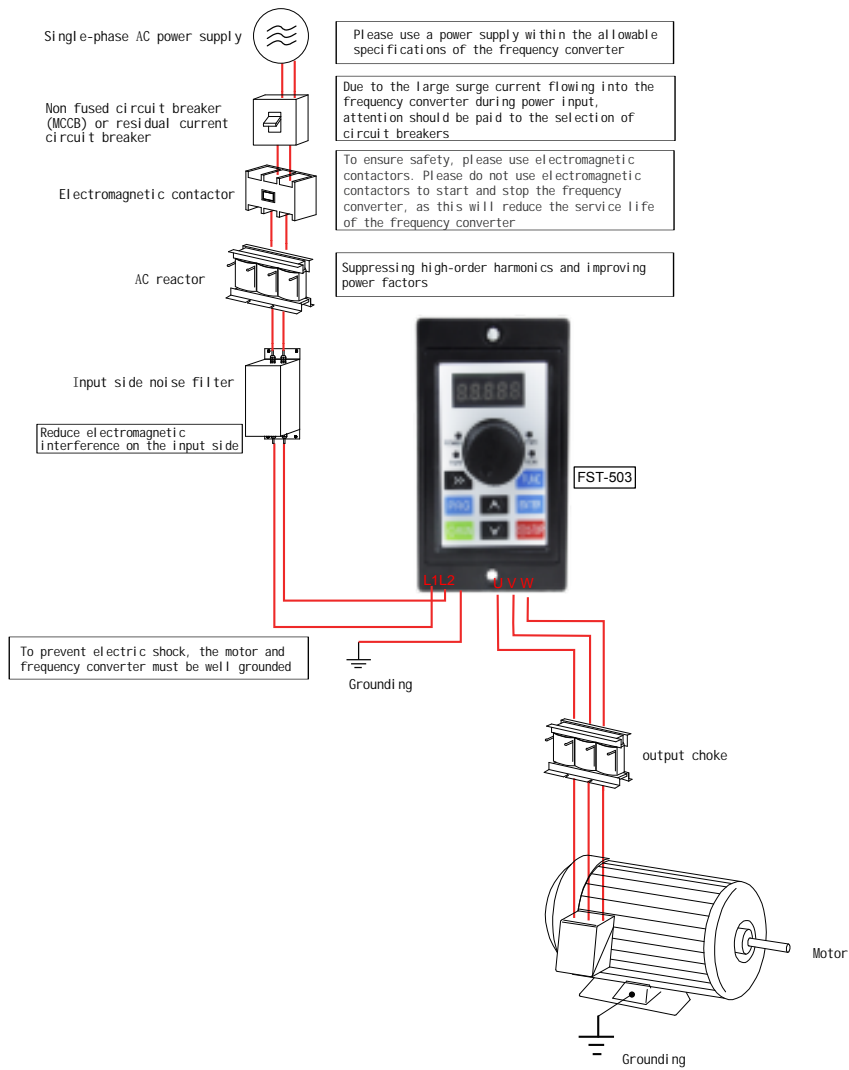

Figure 3-4 Schematic diagram of the peripheral wiring

pay attention to:

- 1) Do not install a capacitor or surge inhibitor on the output side of the converter, which will lead to the failure of the converter or the damage of the capacitor and surge inhibitor;
- 2) The input / output (main loop) of the frequency converter contains harmonic components, which may interfere with the communication equipment of the frequency converter accessories. Therefore, an anti-interference filter is installed to minimize the interference.



## Chapter IV Operation

### 4.1 Introduction of the operation and display interface

#### 4.1.1 Keyboard schematic diagram:

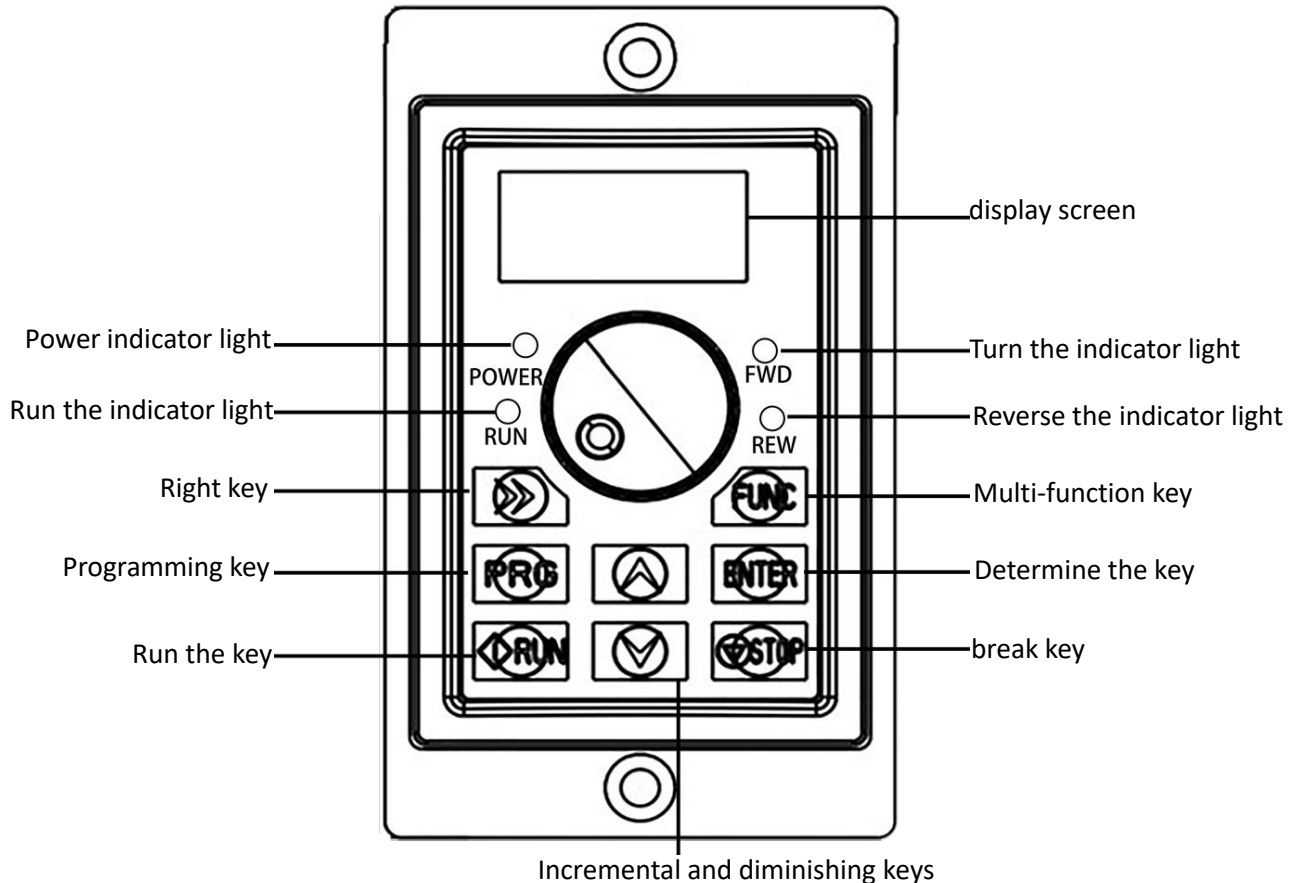

#### 4.1.2 Key function description

Keynote symbol	name	function declaration
	Programming key	Level 1 menu to enter or exit
	Determine the key	Enter the menu screen step by step and confirm the setting parameters
	UP increasing key	Increment of the data or function code
	DOWN decreasing key	Decession of data or functional codes
	Right displacement key	Under the shutdown display interface and running display interface, the display parameters can be selected by the right shift cycle; when modifying the parameters, the modification bit of the parameters can be selected
	Run the key	In the keyboard operation mode, used for running operations

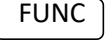
Keynote symbol	name	function declaration
	Stop / reset key	When running status, press this key to stop running operation; this function code F7.16 restriction. In the fault alarm state, all control modes can be reset with the key
	Multi-function key	Select the function switch according to F7.15, which can be defined as the command source, or direction quick switch

#### 4.1.3, indicator light instructions

##### 1) Description of the function indicator light

Indicator lamp name	Indicator light description
RUN	Operation status indicator: when the light is out, the frequency converter is shut down; when the light is on, the frequency converter is in operation;
FWD	Reverse indicator: the light indicates a positive state.
REW	Reverse indicator: The light indicates an inversion state.
POWER	Power indicator, the light is on, the light off indicates the fault state.

#### 4.2 Functional parameter table

FP-00 is set to non-0 value, that is, the parameter protection password is set, the parameter menu must enter the password correctly, cancel the password, FP-00 must be set to 0.

The symbols in the function table are described as follows:

"☆": It means that the set value of this parameter can be changed when the frequency converter is in the shutdown and running state;

"★": It means that the set value of the parameter cannot be changed when the frequency converter is in the running state;

"●": It means that the value of the parameter is the actual detected recorded value and cannot be changed;

"\*": It means that the parameter is "manufacturer parameter", which is only set by the manufacturer and is prohibited from operation.

FC	name	Set the scope	Factory value	change
F0 group Basic function group				
F0-00	Command source selection	0: Operation panel command channel (LED out) 1: Terminal command channel (LED bright) 2: Serial port communication command channel (LED flashing)	0	☆
F0-01	Frequency source selection	0: Digital setting (UP, DOWN adjustment) 1: The panel potentiometer 2: External potentiometer VR control 3: Keep 4: Multi-section speed 5: PLC	0	★

FC	name	Set the scope	Factory value	change
		6: PID 7: VR + panel potentiometer 8: Communication Settings 9: PID + panel potentiometer 10: PID + VR		
F0-02	Value setting the frequency memory selection	0: Don't remember 1: ELECTRIC memory 2: Downtime memory 3: shutdown, power loss are memory	0	☆
F0-03	Preset frequency	0.00Hz~ Maximum frequency (F0-04)	50.00Hz	☆
F0-04	maximum-frequency	50.00Hz~630.00Hz	50.00Hz	★
F0-05	Upper limit frequency source	0: Value setting (F0-06) 1: The panel potentiometer 2: VR control; 3: retention	0	★
F0-06	Upper limit frequency value is set	Lower Limit Frequency (F0-07) ~ Max. Frequency (F0-04)	50.00Hz	☆
F0-07	Lower limit frequency value setting	0.00 Hz to upper limit frequency (F0-06)	0.00Hz	☆
F0-08	Units of the acceleration and deceleration time	0: s (seconds) 1: m (score)	0	★
F0-09	Acceleration time 1	0.00s(m)~300.00s(m)	Model determination	☆
F0-10	Slow down time 1	0.00s(m)~300.00s(m)	Model determination	☆
F0-11	carrier frequency	0.5kHz~16.0kHz	Model determination	☆
F0-12	Running direction	0: The direction is the same 1: The opposite direction	0	☆
F0-13	Acceleration of deceleration time reference frequency	0: Maximum frequency 1: Set the frequency	0	★
F0-14	Runtime frequency UP / DOWN baseline	0: Run frequency 1: Set the frequency	0	☆
F0-15	Secondary frequency source Y selection	0: Number setting (UP / DOWN) 1: The panel potentiometer 2: VR 3: Keep 4: Multi-section speed	0	★

FC	name	Set the scope	Factory value	change
		5: PLC 6: PID 7: VR + panel potentiometer 8: Communication Settings		
F0-16	Auxiliary frequency source Y range selection when superposition	0: relative to the maximum frequency 1: relative to the frequency source X	0	☆
F0-17	Range of the auxiliary frequency source Y upon superposition	0%~150%	100%	☆
F0-18	Frequency source superposition selection	0: Lord 1: Main + auxiliary 2: The main uterus is supplemented by oneself 3: Main and main + auxiliary 4: auxiliary main + auxiliary	0	☆
F0-20	Secondary frequency source offset number set	0.00Hz~ the maximum frequency F0-04	0.00Hz	☆
F0-21	Carrier frequency automatic adjustment selection	0: The carrier is not adjusted with the temperature 1: The carrier wave is automatically adjusted with the temperature	1	☆
F0-22	The Command bundles the primary frequency source	Individual bit: the operation panel command channel 0: No bundling 1: Number setting (UP / DOWN) 2: The panel potentiometer 3: VR 4: Keep 5: Multi-section speed 6: PLC 7: PID 8: VR + panel potentiometer 9: Communication Settings Ten place: terminal command channel, ibid. above Hundred bits: serial port communication command channel, iv. above	000	☆
Motor parameters and V / F control parameters in group F1				
F1-00	The motor is rated power	0.2kW~1.5kW	Model determination	★
F1-01	The motor is rated voltage	0V~240V	Model determination	★

FC	name	Set the scope	Factory value	change
			ation	
F1-02	Rated current of motor	0.1A~7A	Model determination	★
F1-03	Rated frequency of motor	0.01Hz~ maximum frequency (F0-04)	Model determination	★
F1-04	VF curve and load selection	"0" universal constant torque line V / F curve "1" custom multipoint V / F curve The "2" variable torque square V / F curve	0	★
F1-05	Recurrent ascension	0.0%~0.1% (automatic) 0.1%~30.0%	Model determination	☆
F1-06	Torque lift cutoff frequency	0.00Hz~ Maximum frequency (F0-04)	50.00Hz	★
F1-07	The multipoint V / F frequency point f1	0.00Hz~F1-09	0.00Hz	★
F1-08	Multipoint V / F voltage point v1	0.0%~100.0%	0.0%	★
F1-09	Multipoint V / F frequency point f2	F1-07~F1-11	0.00Hz	★
F1-10	Multipoint V / F voltage point v2	0.0%~100.0%	0.0%	★
F1-11	The multipoint V / F frequency point f3	F1-09-Motor rated frequency (F1-03)	0.00Hz	★
F1-12	Multipoint V / F voltage point v3	0.0%~100.0%	0.0%	★
F1-13	Transfer difference compensation coefficient	0.0%~200.0%	0.0%	☆
F1-14	Overexcitation gain	0~200	64	☆
F1-15	no-load current	0.1A~ Motor rated current (F1-02)	Model determination	☆
F1-16	stator resistance	0.001 Ω ~65.535 Ω	Model determination	☆
F1-17	Oscillation inhibits gain	0~100	Model determination	☆
F1-18	Tune selection	0: No operation	0	★

FC	name	Set the scope	Factory value	change
		1: Tune		
F1-19	Inhibition of oscillatory patterns	0~4	1	☆
The F2 group input terminal				
F2-00	S1 terminal function selection	0: No function	1	★
F2-01	The S2 terminal function selection	1: Forward Run (FWD) 2: Reverse Run (REV) 3: Three-line operation control 4: Forward movement (FJOG) 5: Reverse point movement (RJOG) 6: Terminal UP 7: Terminal DOWN 8: Free parking 9: Fault reset (RESET) 10: Operation pause	2	★
F2-02	S3 terminal function selection	11: External fault input is often open 12: External fault input is often closed 13: Multiple speed terminal 1 14: Multiple speed terminal 2 15: Multiple speed terminal 3 16: acceleration and deceleration time selection terminal 17: UP / DOWN set zero reset 18: DC brake	4	★
F2-03	S 4 (Retention extension)	19: acceleration and deceleration ban 20: The PID is paused 21: The PLC state is reset 22: The swing frequency pause 23: Counter input 24: Counter is reset 25: Length count input 26: Length count is reset 27: VR and VR setting swap	8	★

FC	name	Set the scope	Factory value	change
F2-04	S 5 (Retention extension)	28: The frequency source is switched to VR, and it is only valid when F0-18 (frequency source superposition selection) is set to 0 (main). 29: Stop the DC brake enabled 30: Keyboard command source switch 31: Terminal command source switch 32: the first motor and the second motor switch 33: frequency source switching 34: Lock the running frequency 35: Select the primary frequency source 36: Select the auxiliary frequency source 37: Switch between motor 1 and motor 2 in operation	0	★
F2-06	Terminal command mode	0: Two-line 1 1: Two lines 2 2: Three-line 1 3: Three-line 2	0	★
F2-07	Terminal UP / DOWN rate	0.01Hz/s~100.00Hz/s	1.00Hz/s	☆
F2-08	Panel potentiometer minimum input	0.00V~F2-10	0.02V	☆
F2-09	The panel potentiometer minimum input corresponds to the setting	-100.0%~100.0%	0.0%	☆
F2-10	Panel potentiometer maximum input	F2-08~10.00V	10.00V	☆
F2-11	The maximum input of the panel potentiometer corresponds to the setting mode	0: F2-12 1: Set by the panel potentiometer	0	★
F2-12	The maximum input of the panel potentiometer corresponds to the setting	-100.0%~100.0%	100.0%	☆
F2-13	Panel potentiometer input filter time	0.00s~10.00s	0.10S	☆
F2-14	VR minimum input	0.00V~F2-16	0.02V	☆
F2-15	The VR minimum input corresponds to the setting	-100.0%~100.0%	0.0%	☆

FC	name	Set the scope	Factory value	change
F2-16	VR maximum input	F2-14~10.00V	10.00V	☆
F2-17	The VR maximum input corresponds to the setting mode	0: F2-18 1: Set up by the VR	0	★
F2-18	The VR maximum input corresponds to the setting	-100.0%~100.0%	100.0%	☆
F2-19	VR input filtering time	0.00s~10.00s	0.10S	☆
F3 group output terminals				
F3-01	Y 1 output selection	0: No output 1: Frequency converter is in operation # 2: Fault output # 1 3: FDT arrival 4: Frequency arrives 5: Upper limit frequency reaches	2	☆
F3-02	Y2 Output Selection	6: Lower limit frequency reaches 7: Run 1 at zero speed 8: Motor overload forecast alarm 9: frequency converter overload forecast alarm 10: Set the count value for arrival 11: The specified count value arrives 12: Length arrives 13: The PLC completes the cycle 14: Run time arrives 15: Communication control 16: Ready to run 17: Panel potentiometer> VR 18: Zero current is detected 19: External switch signal 20: Keep 21: Fault output 2 22: In the zero-speed operation of 2 # 23: Fault output # 3 24: switch the motor external contactor control signal	1	☆
F3-09	Y1 output delay time	0.0s~3600.0s	0.0s	☆
F3-10	Y2 output delay time	0.0s~3600.0s	0.0s	☆
F4 group start-stop control				
F4-00	starting mode	0: Direct start	0	★



FC	name	Set the scope	Factory value	change
		1: Speed tracking start		
F4-01	Speed tracking method	0 Track from the shutdown frequency 1 Tracking from power frequency (power frequency conversion) 2 follows up from the maximum frequency	0	☆
F4-02	Speed tracking fast and slow	1~100	20	☆
F4-03	Start frequency	0.00Hz~ Maximum frequency (F0-04)	0.00Hz	★
F4-04	Start the frequency hold time	0.0s~36.0s	0.0s	★
F4-05	Start the DC brake current	0%~100%	0%	★
F4-06	Start the DC brake time	0.0s~36.0s	0.0s	★
F4-07	Add deceleration mode	0: linear acceleration and deceleration 1: S-curve acceleration and deceleration A 2: S-curve acceleration and deceleration of B	0	★
F4-08	S curve start time	0.0%~100.0%	20.0%	★
F4-09	S curve end period time	0.0%~100.0%	20.0%	★
F4-10	Downtime method	0: Slow down 1: Free shutdown	0	☆
F4-11	Shutime DC brake start frequency	0.00Hz~ Maximum frequency (F0-04)	0.50Hz	☆
F4-12	Shutime DC brake waiting time	0.0s~36.0s	0.0s	☆
F4-13	Shutime DC brake current	0%~100%	50%	☆
F4-14	Stop the DC brake time	0.0s~36.0s	0.5s	☆
F4-15	Brake utilization rate	0%~100%	100%	☆
F4-18	Speed tracking current size	30%~200%	100%	★
F5 group function				
F5-00	Point movement operation frequency	0.00Hz~ Maximum frequency (F0-04)	2.00Hz	☆
F5-01	Point motion acceleration time	0.00s~300.00s	20.00s	☆
F5-02	Point motion deceleration time	0.00s~300.00s	20.00s	☆
F5-03	Point movement is enabled during the	0: Don't make it 1: Enable	0	☆

FC	name	Set the scope	Factory value	change
	operation			
F5-04	Acceleration time 2	0.00s(m)~300.00s(m)	Model determination	☆
F5-05	Slow down time 2	0.00s(m)~300.00s(m)	Model determination	☆
F5-06	Jump frequency	0.00Hz~ Maximum frequency (F0-04)	0.00Hz	☆
F5-07	Jump frequency amplitude	0.00Hz~ Maximum frequency (F0-04)	0.00Hz	☆
F5-08	Forward and reverse dead zone time	0.0s~100.0s	0.0s	☆
F5-09	Reverse control	0: Allowed inversion; 1: No reversal	0	☆
F5-10	The frequency is lower than the lower limit frequency running action	0: Run at lower frequency (operating frequency below lower) 1: delayed shutdown (operating frequency below lower limit)	0	☆
F5-11	When the frequency is below the lower limit	0.0s~3600.0s	0.0s	☆
F5-12	Set the run time	0h~65535h	0h	☆
F5-13	Run time to reach the action selection	0: Continue running 1: Downtime	0	☆
F5-14	Start protection options	0: invalid 1: valid	0	☆
F5-15	Frequency detection value (FDT level)	0.00Hz~ Maximum frequency (F0-04)	50.00Hz	☆
F5-16	Frequency detection lag value	0.0%~100.0%	5.0%	☆
F5-17	The frequency reaches the detection amplitude	0.0%~100.0%	0.0%	☆
F5-18	Random PWM gain	0~10	0	☆
F5-19	Modulation method selection	0: Asynchronous modulation 1: Synchronous modulation	0	★
F5-20	Quick flow limiting function selection	0: invalid; 1: valid	1	★
F5-21	Wake up frequency	Dormant frequency (F5-23) ~ Maximum frequency (F0-04)	0.00Hz	☆
F5-22	Wake up delay time	0.0s~6500.0s	0.0s	☆

FC	name	Set the scope	Factory value	change
F5-23	The dormancy frequency	0.00Hz~ Wake-Up Frequency (F5-21)	0.00Hz	☆
F5-24	Sleep delay time	0.0s~6500.0s	0.0s	☆
F5-25	Software over-flow point	0.0%~300.0% (rated current of the motor)	200.0%	☆
F5-26	Software overcurrent detection delay time	0.00s (not tested) 0.01s~600.00s	0.00s	☆
F5-37	Selection of dead zone compensation mode	0~1	1	★
F5-38	Heat dissipation fan control	0: The cooling fan runs when the motor is running 1: The cooling fan keeps running after power on	0	☆
F5-39	External switch start frequency	At 0.00Hz~ the maximum frequency	0.00Hz	☆
F5-40	External trip time	0.0s~3600.0s	0.0s	☆
F5-41	Jump-frequency processing mode	0: Not processing during acceleration and deceleration 1: Processing in acceleration and deceleration	0	☆
F5-43	Power-Up time (seconds)	0s~3599s	0	●
F5-44	Power on time (when)	0h~65535h	0	●
F5-45	continue to have	-	-	-
The F6 group has a PID function				
F6-00	PID for a given source	0: F6-01 1: The panel potentiometer 2: VR 3: retain; 4: multiple speed; 5: retain	0	☆
F6-01	PID value setting	0.0%~100.0%	50.0%	☆
F6-02	PID given the time of change	0.0s~3000.0s	0.0s	☆
F6-03	PID feedback source	0: The panel potentiometer 1: VR	0	☆
F6-04	PID application direction	0: Positive effect 1: Counteraction	0	☆
F6-05	PID given the feedback range	0~65535	1000	☆
F6-06	proportional gain P	0.1~100.0	20.0	☆
F6-07	integration time I	0.01s~10.00s	2.00s	☆
F6-08	rate time D	0.000s~10.000s	0.000s	☆
F6-09	Deviation limit	0.0%~100.0%	0.0%	☆

FC	name	Set the scope	Factory value	change
F6-10	The PID operation mode	0: No operation during the shutdown 1: Operation during shutdown	0	☆
F6-11	PID reversal cutoff frequency	At 0.00Hz~ the maximum frequency	0.00Hz	☆
F6-12	The PID mode hibernation switch	0: Turn off the PID mode hibernation function 1: Enable PID mode dormancy function	0	☆
F6-13	Wake up tolerance	0.1%~100%	10.0%	☆
F6-14	Wake up delay	0.1s~6500.0s	0s	☆
F6-15	Poor sleeping capacity	0.1%~100.0%	10.0%	☆
F6-16	The dormancy frequency	0.00Hz~ Maximum frequency (F0-04)	20.00Hz	☆
F6-17	Sleep delay	0.1s~6500.0s	0s	☆
Group F7: pendulum frequency, fixed length, and count				
F7-00	Layout setting method	0: relative to the center frequency 1: Relative to the maximum frequency	0	☆
F7-01	The frequency amplitude	0.00%~100.0%	0.0%	☆
F7-02	The amplitude of the jump frequency	0.0%~50.0%	0.0%	☆
F7-03	Pop frequency cycle	0.01s~300.00s	10.00s	☆
F7-04	The coefficient of the triangular wave rise time	0.1%~100.0%	20.0%	☆
F7-05	Set the length	0m~65535m	1000m	☆
F7-06	current length	0m~65535m	0m	☆
F7-07	Pulse number per meter	0.1~6553.5	100.0	☆
F7-08	Set the gauge value	1~65535	1000	☆
F7-09	Specify the count value	1~65535	1000	☆
F7-10	Load speed display coefficient	0.0001~6.5000	1.0000	☆
F7-11	The load speed shows the decimal point position	The 0:0 digits are in the decimal places 1:1 decimal place 2:2 decimal places In the 3:3 decimal places	1	☆
F7-12	Cumulative running time	0h~65535h	-	●
F7-13	The LED runs to display the parameters	1~65535	799	☆
F7-14	LED shutdown to display the parameters	1~511	51	☆

FC	name	Set the scope	Factory value	change
F7-15	The FUNC key function selection	0: The FUNC is invalid 1: Operation panel command channel and remote command channel (terminal command channel or serial port command channel) switch 2: forward and reverse switch 3: Positive point movement	0	★
F7-16	The STOP key function	0: STOP shutdown is valid only under keyboard control 1: The STOP key shutdown function is valid in any control mode	0	☆
F7-17	Software version number	0.01~655.35	-	●
F8 group polysegment velocity, PLC				
F8-00	Multi-segment speed 0 given way	0: Function code F8-01 is given 1: The panel potentiometer 2: VR 3: Keep 4: PID 5: preset frequency (F0-03), UP / DOWN can be modified	0	★
F8-01	Multi-segment speed 0	-100.0%~100.0% (upper limit frequency F0-05)	0.0%	☆
F8-02	Multi-segment speed 1	-100.0%~100.0% (upper limit frequency F0-05)	0.0%	☆
F8-03	Multi-segment speed 2	-100.0%~100.0% (upper limit frequency F0-05)	0.0%	☆
F8-04	Multi-segment speed 3	-100.0%~100.0% (upper limit frequency F0-05)	0.0%	☆
F8-05	Multi-segment speed 4	-100.0%~100.0% (upper limit frequency F0-05)	0.0%	☆
F8-06	Multi-segment speed 5	-100.0%~100.0% (upper limit frequency F0-05)	0.0%	☆
F8-07	Multi-segment speed 6	-100.0%~100.0% (upper limit frequency F0-05)	0.0%	☆
F8-08	Multi-segment speed 7	-100.0%~100.0% (upper limit frequency F0-05)	0.0%	☆
F8-09	PLC run mode	0: Stop after a single operation 1: Maintain the final value at the end of a single run 2: Always cycle	0	☆
F8-10	PLC drop memory selection	One bit: power loss memory selection 0: Power loss without memory 1: ELECTRIC memory	0	☆
F8-11	PLC running time units	0: s (s); 1: h (hours); 2: min (min)	0	☆
F8-12	PLC paragraph 0 run time	0.0s(h)~6553.5s(h)	0.0s(h)	☆

FC	name	Set the scope	Factory value	change
F8-13	Selection of the acceleration and deceleration time of the PLC in paragraph 0	0: acceleration and deceleration time 1 1: acceleration and deceleration time 2	0	☆
F8-14	PLC paragraph 1 run time	0.0s(h)~6553.5s(h)	0.0s(h)	☆
F8-15	acceleration and deceleration time selection of PLC paragraph 1	0: acceleration and deceleration time 1 1: acceleration and deceleration time 2	0	☆
F8-16	PLC paragraph 2 run time	0.0s(h)~6553.5s(h)	0.0s(h)	☆
F8-17	Paragraph 2 of acceleration and deceleration time selection of PLC	0: acceleration and deceleration time 1 1: acceleration and deceleration time 2	0	☆
F8-18	PLC paragraph 3 run time	0.0s(h)~6553.5s(h)	0.0s(h)	☆
F8-19	Paragraph 3 of acceleration and deceleration time selection of PLC	0: acceleration and deceleration time 1 1: acceleration and deceleration time 2	0	☆
F8-20	PLC paragraph 4 run time	0.0s(h)~6553.5s(h)	0.0s(h)	☆
F8-21	Paragraph 4 of acceleration and deceleration time selection of PLC	0: acceleration and deceleration time 1 1: acceleration and deceleration time 2	0	☆
F8-22	PLC paragraph 5 run time	0.0s(h)~6553.5s(h)	0.0s(h)	☆
F8-23	acceleration and deceleration time selection of PLC paragraph 5	0: acceleration and deceleration time 1 1: acceleration and deceleration time 2	0	☆
F8-24	PLC paragraph 6 run time	0.0s(h)~6553.5s(h)	0.0s(h)	☆
F8-25	acceleration and deceleration time of PLC paragraph 6	0: acceleration and deceleration time 1 1: acceleration and deceleration time 2	0	☆
F8-26	PLC paragraph 7 run time	0.0s(h)~6553.5s(h)	0.0s(h)	☆

FC	name	Set the scope	Factory value	change
F8-27	acceleration and deceleration time selection of PLC paragraph 7	0: acceleration and deceleration time 1 1: acceleration and deceleration time 2	0	☆
The F9 group was retained				
F9-00	continue to have	-	-	-
The FA group communication parameters				
FA-00	Baud rate	1: 600BPS 2: 1200BPS 3: 2400BPS 4: 4800BPS 5: 9600BPS 6: 19200BPS 7: 38400BPS	5	☆
FA-01	data format	0: no check; 1: even check; 2: odd check	0	☆
FA-02	This machine address	0~247,0 is for the broadcast address	1	☆
FA-03	answering delay	0ms~20ms	2ms	☆
FA-04	Communication timeout time	0.0s~60.0s	0.0s	☆
FB failure and protection				
FB-00	Motor overload protection selection	0: Invalid 1: valid	1	☆
FB-01	Motor overload protection gain	0.20~10.00	1.00	☆
FB-02	Motor overload warning factor	50%~100%	80%	☆
FB-07	Power-on short-circuit to the ground protection function	0: Invalid 1: valid	1	☆
FB-08	Loading protection function	0: Invalid; 1: valid	0	☆
FB-13	Number of automatic reset	0~10	0	☆
FB-14	Selection of fault relay action during fault automatic reset	0: No action 1: action	0	☆
FB-15	Automatic fault reset interval time	0.1s~60.0s	1.0s	☆
FB-16	Failure automatic reset	0.1h~1000.0h	1.0h	☆

FC	name	Set the scope	Factory value	change
	times clear time			
FB-17	Enter the missing phase-protection selection	0: Invalid; 1: valid	1	☆
FB-18	Output the missing phase protection selection	0: Invalid; 1: valid	1	☆
FB-19	Radator temperature of inverter module	-10°C ~ 100°C	-	●
FB-20	First-time fault type	0: No fault 1: Keep 2: accelerated overcurrent (ERR 02) 3: deceleration overcurrent (ERR 03) 4: constant speed over current (ERR 04) 5: accelerated overvoltage (ERR 05) 6: deceleration overvoltage (ERR 06) 7: constant speed overvoltage (ERR 07) 8: Buffered resistance overload fault (ERR 08) 9: Undervoltage fault (ERR 09)		
FB-21	The second failure type	10: Frequter overload (ERR 10) 11: Motor overload (ERR 11) 12: Input the missing phase (ERR 12) 13: Output phase absence (ERR 13) 14: Module overheating (ERR 14) 15: External fault (ERR 15) 16: Communication timeout fault (ERR 16) 17: Contactor suction fault (ERR 17) 18: Current detection fault (ERR 18)	-	●
FB-22	Third (most recent) failure type	19: Motor Tuning fault (ERR 19) 20: Hold (ERR 20) 21: EEPROM Read and write fault (ERR 21) 22: Retention (ERR 22) 23: Motor short circuit to ground fault (ERR 23) 24: Hold (ERR 24) 25: Retention (ERR 25) 26: Run time arrival (ERR 26) 31: Software overcurrent fault (ERR 31) 40: Fast current limit timeout fault (ERR 40) 41: Switching motor fault (ERR 41)		
FB-23	Frequency of failure	-	-	●
FB-24	Current in case of failure	-	-	●



FC	name	Set the scope	Factory value	change
FB-25	Bus voltage at failure	-	-	●
FB-26	Enter the terminal status during the fault	-	-	●
FB-27	Output terminal status during the failure	-	-	●
FB-28	Selection of underpressure points	60.0%~140.0% Three-phase: 100.0% corresponding to the bus voltage 350.0V Two phases: 100.0% corresponding to the bus voltage 200.0V	100.0%	☆
FB-29	Zero-current detection level	0.0%~300.0% 100.0% corresponds to the motor rated current	5.0%	☆
FB-30	Zero-current detection delay time	0.01s~600.00s	0.10s	☆
2nd motor parameters in FC group				
FC-00	Second motor rated power	0.2kW~1000.0kW	Model determination	★
FC-01	The 2nd motor is rated at the same voltage	0V~480V	Model determination	★
FC-02	The 2nd motor has a rated current	0.1A~6553.5A	Model determination	★
FC-03	The 2nd motor is rated at a constant frequency	0.01Hz~ maximum frequency (F0-04)	Model determination	★
FC-04	Second motor No-load current	0.1A~6500.0A	Model determination	☆
FC-05	The 2nd motor stator resistance	0.001 Ω ~65.535 Ω	Model determination	☆
FC-06	2nd motor torque lift	0.0% (automatic) 0.1%~30.0%	Model determination	☆
FC-07	2nd motor differential compensation coefficient	0.0%~200.0%	0.00%	☆
FC-08	Second motor oscillation suppression gain	0~100	Model determination	☆

FC	name	Set the scope	Factory value	change
			ation	
FC-09	The 2nd motor acceleration and deceleration time selection	0: Same as for the first electric motor 1: acceleration and deceleration time 1	0	☆
The AI-corrected functional code in the FD group				
FD-00	Measured voltage of the panel potentiometer 1	0.50 V~4.00V	2.00V	☆
FD-01	Panel potentiometer sampling voltage of 1	0.50 V~4.00V	2.00V	☆
FD-02	Measured voltage of the panel potentiometer: 2	6.00V~9.99V	8.00V	☆
FD-03	Panel potentiometer sampling voltage of 2	6.00V~9.99V	8.00V	☆
FD-04	VR measured voltage 1	0.50 V~4.00V	2.00V	☆
FD-05	A VR sampling voltage of 1	0.50 V~4.00V	2.00V	☆
FD-06	VR measured voltage 2	6.00V~9.99V	8.00V	☆
FD-07	VR sampling voltage 2	6.00V~9.99V	8.00V	☆
Manufacturers' parameters of the FF group				
FF-00	Manufacturer password	continue to have	continue to have	*
The FP group user password				
FP-00	User password	0~65535	0	☆
FP-01	Parameter initialization	0: No operation 1: restore the factory value 2: Clear the record information 3: Clear zero and power on time	0	☆
FP-02	Power time correction coefficient	0.60~1.50	1.00	★

## Chapter V Fault diagnosis and Countermeasures

### 5.1 Fault alarm and countermeasures

FST-503 frequency converter has many warning information and protection functions. Once an abnormal fault occurs, the protection function acts, the converter stops output, the converter fault relay contact acts, and the fault code is displayed on the display panel of the converter. Before seeking the service, the user can first conduct self-examination according to the prompts in this section, analyze the cause of the fault, and find out the solution. If you cannot find a solution, please seek technical support, contact the agent of your frequency converter or contact our company directly.

Fault name	Fault code	Troubleshooting	Troubleshooting countermeasures
Accelerate over current	Err02	<ol style="list-style-type: none"> <li>1. The frequency converter output circuit has grounding or short circuit</li> <li>2. The acceleration time is too short</li> <li>3. Manual torque lifting or V / F curve is not appropriate</li> <li>4. Low voltage</li> <li>5. Start the rotating motor</li> <li>6. Sudden loading during acceleration</li> <li>7. The selection of frequency converter is too small</li> </ol>	<ol style="list-style-type: none"> <li>1. Troubleshoot the peripheral faults</li> <li>2. Increase the acceleration time</li> <li>3. Adjust the manual lifting torque or V / F curve. 4</li> <li>5. Select the speed tracking start or start after the motor stops</li> <li>6. Cancel the sudden adding load</li> <li>7. Choose the frequency converter with a larger power level</li> </ol>
Slow down over current	Err03	<ol style="list-style-type: none"> <li>1. The frequency converter output circuit has grounding or short circuit</li> <li>2. The deceleration time is too short</li> <li>3. Low voltage</li> <li>4. Add the load suddenly during the deceleration process</li> <li>5. No brake unit and brake resistance are installed</li> </ol>	<ol style="list-style-type: none"> <li>1. Troubleshoot the peripheral faults</li> <li>2. Increase the deceleration time</li> <li>3. Adjust the voltage to the normal range</li> <li>4. Cancel the sudden adding load</li> <li>5. Install the brake unit and the resistance</li> </ol>
Constant speed over current	Err04	<ol style="list-style-type: none"> <li>1. Whether there is a short circuit or leakage current in the output circuit of the frequency converter</li> <li>2. Whether there is a sudden adding load in the operation</li> <li>3. The load is too large, and the frequency converter selection is too small</li> </ol>	<ol style="list-style-type: none"> <li>1. Troubleshoot the peripheral faults</li> <li>2. Cancel the sudden adding load</li> <li>3. Choose the frequency converter with a larger power level or reduce the load</li> </ol>
Accelerated overvoltage	Err05	<ol style="list-style-type: none"> <li>1. The input voltage is too high</li> <li>2. There is an external force dragging the motor in the acceleration process</li> <li>4. No brake unit and brake resistance</li> </ol>	<ol style="list-style-type: none"> <li>1. Adjust the voltage to the normal range</li> <li>2. Cancel additional power or add brake resistance</li> </ol>

Fault name	Fault code	Troubleshooting	Troubleshooting countermeasures
		are installed	3. Increase the acceleration time 4. Install the brake unit and the resistance
Slow down over voltage	Err06	1. The input voltage is too high 2. External force drags the motor during the deceleration process. 3. No brake unit and brake resistance are installed	1. Adjust the voltage to the normal range 2. Cancel the additional power or install the brake resistance. 3. Increase the deceleration time 4. Install the brake unit and the resistance
Constant speed overvoltage	Err07	1. The input voltage is too high 2. There is an external force dragging the motor during the operation process	1. Adjust the voltage to the normal range 2. Cancel additional power or add brake resistance
Buffer resistance overload fault	Err08	1. The input voltage is not within the range specified in the specification 2. The input voltage instability causes the bus voltage to beat frequently near the undervoltage point	1. Adjust the voltage to the range required by the specification 2. Wait for at least 5 minutes and make sure the input voltage is normal before powering on.
Underpressure failure	Err09	1. Instantaneous power failure 2. The input voltage of the frequency converter is not within the range required by the specification 3. Bus voltage is abnormal 4. The rectification bridge and buffer resistance are not normal 5. Drive board is abnormal 6. Abnormal control board	1. Resignation failure 2. Adjust the voltage to the normal range; 3. Seek technical support 4. Seek technical support 5. Seek technical support 6. Seek technical support
Frequency converter overload	Err10	1. Whether the load is too large or the motor is blocked 2. The selection of the frequency converter is too small	1. Reduce the load and check the motor and mechanical condition 2. Choose the frequency converter with a larger power level
Motor overload	Err11	1. Whether the motor protection parameter FB-01 is set. 2. Whether the load is too large or the motor blocked 3. The selection of the frequency converter is too small	1. Set this parameter correctly 2. Reduce the load and check the motor and mechanical conditions 3. Choose the frequency converter with a larger power level
Input the missing phase	Err12	1. Three-phase input power supply is abnormal	1. Check and eliminate the problems existing in the peripheral lines

Fault name	Fault code	Troubleshooting	Troubleshooting countermeasures
		2. Drive board is abnormal 3. Main control board is abnormal	2. Seek technical support 3. Seek technical support
Output lack of phase	Err13	1. The lead from the frequency converter to the motor is abnormal 2. The three-phase output of the frequency converter is unbalanced when the motor is running. 3 4. Abnormal module	1. Troubleshoot the peripheral faults 2. Check whether the three-phase winding of the motor is normal and troubleshooting 3. Technical support 4. 4 technical support
The module overheating	Err14	1. The ambient temperature is too high 2. The air duct is blocked 3. Fan damage 5. The inverter module is damaged	1. Reduce the ambient temperature 2. Clean the air duct 3. Change the fan 5. Seek technical support and replace the inverter module
External equipment failure	Err15	1. Press STOP in non-keyboard operation 2. Enter the external fault signal through the multifunctional terminal S 3. In case of stall condition, stop with STOP	1. Reset operation 2. Check and troubleshoot external faults 3. Reset operation
Communication timeout failure	Err16	1. The upper computer is not working properly 2. The RS 485 communication line is not normal 3. Porter rate FA-00 is not set correctly 4. Communication parameter FA group is not set correctly	1. Check the wiring of the upper position machine 2. Check the communication cable 3. Set the communication extension card type correctly 4. Set the communication parameters correctly
Contactor suction failure	Err17	1. Power supply of contactor 24v is abnormal 2. Other faults	1. Replace the contactor 2. Seek technical support
Current detection failure	Err18	1. Check the Hall device abnormalities 2. Drive board is abnormal	1. Seek technical support and replace the Hall devices 2. Seek technical support and replace the drive board
Motor tuning fault	Err19	1. Motor parameters are not set according to the nameplate 2. Parameter identification process timeout	1. Set the motor parameters correctly according to the nameplate 2. Check the frequency converter to the motor lead line
EEPROM Read and write fault	Err21	1. The EEPROM chip is damaged	1. Seek technical support and replace the main control board

Fault name	Fault code	Troubleshooting	Troubleshooting countermeasures
Short circuit to ground fault	Err23	1. Motor is short-circuit to the ground 2. The motor does not short circuit to the ground	1. Replace the cable or the motor 2. Replace the drive panel
Run-time arrival fault	Err26	1. The cumulative running time reaches the set value	1. Refer to F5-13 (run time arrival action selection)
Software over-current failure	Err31	-	Refer to F5-25 (software overpoint)
Fast current limit timeout failure	Err40	1. The acceleration and deceleration time is too short 2. Torque lift or V / F curve is inappropriate 3. Start the rotating motor 4. Heavy load	1. Increase the acceleration and deceleration time 2. Adjust the torque lift or V / F curve 3. Select speed tracking to start or start after the motor stops 4. Increase the power of the frequency converter
Switch motor fault	Err41	1. Change the current motor selection by the terminal during the operation of the frequency converter 2. It is not switched in the operating state of the frequency converter	1. Switch the motor after the inverter is stopped 2. Seek technical support

## 5.2 Common faults and their handling methods

The following faults may be encountered during the use of the frequency converter, please refer to the following methods for simple fault analysis:

order number	fault phenomenon	Possible cause	resolvent
1	No display or scrambled code	The frequency converter input power supply is abnormal. Poor 8-core and 16-core wiring contact between the drive board and the control board. Internal devices of the inverter are damaged.	Check the input power supply. Replug 8-core and 16-core wiring. Seek manufacturer services.
2	Power on the "Err 23" alarm	Motor or output line short circuit to the ground. Frequency converter damage.	Measure the insulation of the motor and the output lines with a shake meter. Seek manufacturer services.
3	The power converter shows normally, displays	The fan is damaged or blocked.	Change the fan.

order number	fault phenomenon	Possible cause	resolvent
	"HC" after operation and stops immediately		
4	The Err 14 (module overheating) fault is reported frequently	The carrier frequency setting is too high. Damaged fan or blocked air duct. Damage of internal components of frequency converter (thermocouple or other)	Reduce load frequency. Replace the fan and clean up the air duct. Seek manufacturer services.
5	The motor does not rotate after the inverter runs	The motor is damaged or blocked rotation. Incorrect parameter settings.	Replace the motor or remove the mechanical faults. Check and reset.
6	The S terminal fails	Wrong parameter set. wiring error. Control board failure.	Check and reset the relevant parameters. rewiring. Seek manufacturer services.
7	The frequency converter frequently reports the overcurrent and overvoltage faults	Motor parameters set correctly. acceleration and deceleration time is not appropriate. fluctuation of load.	Reset the F1 group parameters. Set the appropriate acceleration and deceleration time. Seek manufacturer services.
8	Fast current limit timeout failure	Motor parameters set correctly. acceleration and deceleration time is not appropriate. fluctuation of load.	Increase the acceleration and deceleration time. Reduce (F1-21) overdrain action current. Increase the frequency converter power.

## Chapter VI Communication Agreement

In FST-503 series frequency converter, RS485 communication interface is provided, and users can realize centralized control through PC / PLC (set the frequency converter operation command, function code parameters, read the working status and fault information of the frequency converter, etc.) to meet the specific use requirements. If the communication port of the external device is RS232, an additional RS232 / RS485 conversion device is required.

### 6.1 Agreement Content

The serial communication protocol defines the information content and usage format transmitted in the serial communication. This includes: host polling (or broadcast) format; host coding method, including: required action function code, transmission data and error check. The response of the slave also adopts the same structure, including: action confirmation, return data and error verification, etc. If the slave has an error while receiving the information, or cannot complete the action required by the host, the fault information will be returned to the host.

### 6.2 Application mode

The inverter is connected to the "single-master and multi-slave" PC / PLC control network with RS485 bus.

### 6.3 Bus structure

#### 1. Interface mode

The RS485 hardware interface. If the communication port of the external device is RS232, an additional RS232 / RS485 conversion device is required.

#### 2. Transmission mode

Asynchronous serial, semi-duplex transmission mode. At the same time the host and slave can only have one send data and the other can only receive data. In the process of serial asynchronous communication, the data is sent in the form of packets, frame by frame.

#### 3. Topology

Single-host multi-slave system. The set range of the slave address is 1 to 247, and 0 is the broadcast address. The slave address in the network must be unique.

### 6.4 Agreement description

FST-503 series frequency converter communication protocol is an asynchronous serial master and slave Modbus communication protocol, only one device (host) in the network can establish the protocol (called "query / command"). Other devices (slave) can only respond to the host by providing data to the "query / command" of the host, or according to the "Query / command" of the host. The host machine here refers to the personal computer (PC), industrial control equipment or programmable logic controller (PLC), etc., and the slave machine refers to the FST-503 frequency converter. The host can communicate with a slave alone and broadcast information to all downmachines. For the individually accessed host "query / command", the slave will return a message (called a response), for the broadcast information sent by the host, the slave does not need to feedback information to the host.



## 6.5 Communication data structure

The Modbus protocol communication data format of FST-503 series inverter is as follows:

In RTU mode, message sending starts at a minimum of 3.5 characters. The first domain to transport is the device address. The transfer character that you can use is a hex of 0...9,A...F。 The network device constantly detects the network bus, including during the pause interval. When the first domain (address domain) receives it, each device decodes it to determine whether it is sent to it. After the last transmission character, a pause of at least 3.5 character time calibrates the end of the message. A new message can start after this pause.

The entire message frame must be transmitted as a continuous stream. If there is a pause time of more than 1.5 characters before the frame completes, the receiving device will refresh the incomplete message and assume that the next byte is the address domain for a new message. Similarly, if a new message starts in less than 3.5 characters, the receiving device will regard it as a continuation of the previous message. This would lead to an error because the value in the final CRC domain could not be correct.

### 1. RTU frame format:

Frame-head, START	At least 3.5 character time
Deliver address for the ADDR	Address: 0~247
command code CMD	03: Read the slave parameters; 06: Write the slave parameters
Data Content DATA (N-1)	data content: Functional code parameter address, number of functional code parameters, value of functional code parameters, etc.
Data Content DATA (N-2)	
.....	
Data content, DATA 0	
CRC CHK Low level	Detection value:
CRC CHK High level	CRC price.
END	At least 3.5 character time

### 2. CMD (command instruction) and DATA (data word description)

Command code: 03H, read N words (Word) (up to 12 words).

For example, read two consecutive function codes F0-10 and F0-11 from the inverter with address 01, and the address of F0-10 is F 00 AH;

ADDR	01H
CMD	03H
The opening address is high	F0H
The address of the beginning is low	0AH
High number of registers	00H
Low number of registers	02H
CRC CHK Low level	Its CRC CHK-value remains to be calculated
CRC CHK High level	

### Responses information from the machine

ADDR	01H
CMD	03H
Number of bytes	04H
Data F002H High Level	00H

Data F002H low	00H
Data F003H High Level	00H
CRC CHK Low level	Its CRC CHK-value remains to be calculated
CRC CHK High level	

Command code: 06H, write a word (Word).

For example, write 5000 (1388H) to the F004H address of the slave address 02H frequency converter.

Host command information

ADDR	02H
CMD	06H
High data address	F0H
Low-level of data address	04H
Data content is at a high level	13H
Data content is low	88H
CRC CHK Low level	Its CRC CHK-value remains to be calculated
CRC CHK High level	

Responses information from the machine

ADDR	02H
CMD	06H
High data address	F0H
Low-level of data address	04H
Data content is at a high level	13H
Data content is low	88H
CRC CHK Low level	Its CRC CHK-value remains to be calculated
CRC CHK High level	

### 3、 Verification mode —— CRC calibration mode: CRC (Cyclical Redundancy Check)

Using the RTU frame format, the message includes an error detection domain based on the CRC method. The CRC domain detects the content of the entire message. The CRC domain is two bytes containing a binary value of 16 bits. It is calculated by the transmission device and then added to the message. The receiving device recalculates the CRC that has received the message and compares the value in the received CRC domain, and if the two CRC values are not equal, the transmission error occurs.

CRC is done by first saving 0xFFFF and then calling a process to process the continuous 8-bit bytes in the message with the value in the current register. Only the 8 Bit data in each character is valid for the CRC, and both the start and stop bits and the parity bits are invalid.

During CRC generation, each 8-bit character is different from the register content or (XOR) separately, and the result is moved towards the lowest effective bit, and the highest effective bit is filled with 0. The LSB was extracted for detection, not performed if LSB was 1, register alone and preset values were different, or if LSB was 0. The entire procedure was repeated 8 times. After the last digit (8th digit) is completed, the next 8-bit byte is separately different from the current value of the register. The value in the final register is the CRC value after all the bytes in the message are executed.

When CRC is added to the message, low bytes join first, then high bytes. The CRC simple functions are as follows:

```

unsigned int CrcValueCalc(const unsigned int *data, unsigned int length)
{
    unsigned int crcValue = 0xffff;
    int i;
    while (length--)
    {
        crcValue ^= *data++;
        for (i = 8 - 1; i >= 0; i--)
        {
            if (crcValue & 0x0001)
            {
                crcValue = (crcValue >> 1) ^ 0xa001;
            }
            else
            {
                crcValue = crcValue >> 1;
            }
        }
    }
    return (crcValue);
}

```

#### 4、 Address definition of the communication parameter

This part is the content of communication, used to control the operation of the frequency converter, frequency converter status and related parameter setting.

Read and write function code parameters (some function codes cannot be changed, only for manufacturers):

Function code parameter address marking rule:

Represent the rule with the function code group number and the reference code as the parameter address:

High Level Bytes: F 0 to FF

Low Bytes: 00 to FF

Such as: F3-12, the address is expressed as F30C;

[Note] FF group: manufacturer parameters. Users do not allow access to the FF group.

Some parameters cannot be changed when the frequency converter is in operation; some parameters cannot be changed regardless of the state of the inverter; change the function code parameters, pay attention to the setting range, units, and relevant instructions.

In addition, because EEPROM is frequently stored, will reduce the service life of EEPROM, so some function codes in the communication mode, do not need to store, as long as the change of the value in RAM. To achieve this function, as long as the high F of the function code address into 0 can be achieved.

The corresponding function code address is indicated as follows:

High-level byte: 00~0F

Low Bytes: 00 to FF

For example, the function code F3-12 is not stored in EEPROM, and the address is 030C;

Such an address is an invalid address when reading the functional code.

Stop / operation parameters section:

Parameter address	parametric description
1000H	Communication set frequency value (-10000~10000) (decimal)
1001H	running frequency
1002H	busbar voltage
1003H	output voltage
1004H	output
1005H	output power
1006H	continue to have
1007H	continue to have
1008H	S input mode
1009H	M output state
100AH	Panel potentiometer voltage
100BH	VR voltage
100CH	continue to have
100DH	count value
100EH	Length value
100FH	loading speed
1010H	PID setting
1011H	PID feedback
1012H	PLC step

pay attention to:

- For the parameters of this part, the communication set frequency value is the percentage of the maximum frequency (-100.00%~100.00%), which can be read and written by communication. All remaining parameters are read-only.

Control command input to frequency converter: (write only)

command address	Command function
2000H	0001: Forward turn operation
	0002: reverse operation
	0003: Positive turning point movement
	0004: reverse point movement
	0005: Free shutdown
	0006: Stop according to the shutdown mode (F4-10)
	0007: Fault reset
	0100: To restore the factory value
	0101: Clear the record information

pay attention to:

- For 0100H (restore factory value) and 0101H (clear record information), the password lock must be lifted first, see the parameter lock password check (4000H command address);
- If there is a user password (FP-00 is not 0), write the correct user password to 4000H command address; if there is no user password (FP-00 is 0), you must write 0 to 4000H command address;

- After "unlocking", the upper computer obtains the permission to obtain the communication recovery factory value and communication clearing record information. If there is no communication within 5 minutes, the permission is invalid. You must regain to obtain this permission.

Read the frequency converter status: (read-only)

status word address	State word function
3000H	0001: Forward turn operation
	0002: reverse operation
	0003: shut down

Parameter lock password check: (if 8888H, the password check passed)

Password address	Enter the contents of the password
4000H	*****

Parameter lock command; (write only)

Lock the password command address	Lock the password command content
5000H	0001: Lock the system command code

Digital output terminal control; (write only)

Command word address	Command function
6000H	BIT 0: Y1 output control BIT 1: Y2 output control BIT 2: Retention; BIT 3: Retention; BIT 4: Retention

Analog output AO1 control: (write only)

Command word address	Command function
7000H	0~7fff representation 0%~100%

Pulse (PULSE) Output Control: (write only)

Lock the password command word address	Lock the password command function
A 000H	0~7fff representation 0%~100%

Frequeter fault description:

Fault address of the frequency converter	Inverter fault information
8000H	0000: No fault 0001: Hold on 0002: Accelerated overcurrent 0003: deceleration overcurrent 0004: Constant-speed over-current 0005: accelerated overvoltage 0006: decelerated overvoltage 0007: Constant-speed over-voltage 0008: Buffered resistance to overload

	0009: undervoltage fault 000A: frequency converter overload 000B: Motor overload 000C: Enter the missing phase 000D: output output phase 000E: the module is overheating 000F: External failure 0010: Communication failure 0011: Contactor fault 0012: Current detection fault 0013: Motor tuning fault 0014: Hold on 0015: EEPROM Read and write fault 0016: reserved 0017: Power on to ground short circuit fault 0018,0019: reserved 001A: Running time reaches fault 001F: software overcurrent fault 0028: Fast current limit timeout fault 0029: Switch the motor fault
--	---

Communication fault information description data (fault code):

Communication fault address	Fault function description
8001H	0000: No fault 0001: Password is wrong 0002: Command code error 0003: CRC check error 0004: Invalid address 0005: Invalid parameter 0006: Invalid parameter change 0007: The system is locked 0008: is storing the parameters

### 6.6 Description of the communication parameters of the FA group

FC	function definition	Factory value	Set the scope	parameter declaration
FA-00	Baud rate	5	1: 600BPS 2: 1200BPS 3: 2400BPS 4: 4800BPS 5: 9600BPS 6: 19200BPS 7: 38400BPS	This parameter is used to set the data transmission rate between the upper computer computer and the frequency converter.(The baud rate set by the upper machine and the frequency converter must be consistent, otherwise, the communication cannot be carried out, the greater the baud rate, the faster the communication speed)
FA-01	data format	0	0: No check: Data format <8-N-2>	When selected with even or odd check, the length of each byte is 11 bits, with 1 bit starting bit, 8 bit data bits, 1 bit check bit, and 1 bit end bit. When

			1: Coupling test: Data format <8-E-1> 2: odd check: data format <8-O-1>	selecting no check, each byte length is 11 bits, with 1 start bit, 8 data bits, and 2 end bits. The data format set by the upper computer and the inverter must be consistent, otherwise, the communication cannot be carried out
FA-02	This machine address	1	0~247,0 is for the broadcast address	This function code is used to identify the address of this frequency converter. The local address is unique (except the broadcast address), which is the basis of realizing the point-to-point communication between the upper computer and the frequency converter.(When the local address is set to 0, it is the broadcast address, and can only receive and execute the broadcast command of the host computer.)
FA-03	Response delay	2ms	0~20ms	When the inverter receives the frame matching the native address, the delay time starts to return the answer frame begins.
FA-04	Communication timeout time	0.0s	0.0 ~60.0s	Communication timeout is not detected when this parameter is set to 0.0s.

pay attention to:

- Too short response delay may cause the upper computer to receive it. If the response delay is less than the system processing time, the response delay shall be subject to the system processing time; If the response delay is greater than the system processing time, the system will send the data to the upper computer.
- When the communication exceeds the time, the frequency converter does not receive the communication signal after the time, the frequency converter will report the communication timeout fault (Err 16). Usually, it is set to be invalid, if you set this parameter in a continuous communication system, you can monitor the communication status.